

### WIRING AND COMMISSIONING INFORMATION FOR SATCHWELL MICRONET TOUCH SCREEN

#### APPLICATION

The Satchwell MicroNet Touch Screen Display (Touch Screen) is a graphical LCD display that allows a user to view and configure parameters, and view parameter values, for multiple controllers on a Native Communications Protocol (NCP), ARCNET® or LONWORKS communications network.

The Touch Screen is available as a panel-mount device, or can be wall or DIN-rail mounted using the MN-DK kit. The Touch Screen (MN50-TS-NCP) can also be mounted in an NCP MN550 or MN650 controller.

The touch-sensitive keypad works easily with the screen's intuitive graphical representation of common control parameters. The display, whose characteristics are configured from the VisiSat Configuration Tool, shows a series of 16 subscreens, each of which gives access to controller parameters (16 parameters per subscreen for NCP and ARCNET Touch Screens, or 8 parameters per subscreen for

LONWORKS Touch Screens). LONWORKS Touch Screens also have built-in holiday and time schedules.

Controller parameters can also be configured to cause alarm indications on the Touch Screen.

The Touch Screen contains a built-in Real Time Clock (RTC) that can be configured to be the master timekeeper for a network. A Lithium battery provides backup power for the RTC and 32Kb static RAM (350 days life at continuous discharge).

The display parameters are configured from the VisiSat™ Configuration Tool.

The Touch Screen configuration is saved on EEPROM, providing protection from power failure.

#### SPECIFICATION

Order Type	Description	Voltage	Display
MN50-TSP-NCP	MicroNet NCP Touch Screen - Panel Mounting	24Vac, 50/60Hz	NCP
MN50-TS-NCP	MicroNet NCP Touch Screen - Controller or Wall* Mounting		
MN50-TSP-ARC	MicroNet ARCNET Touch Screen - Panel Mounting		ARCNET
MN50-TS-ARC	MicroNet ARCNET Touch Screen - Wall Mounting*		
MNL-TSP-100	MicroNet LONWORKS® Touch Screen - Panel Mounting		LONWORKS
MNL-TS-100	MicroNet LONWORKS Touch Screen - Wall Mounting*		

\*MN-DK is required for wall mounting.



#### Data Sheets

DS 10.050 - MN Touch  
DS 10.201 - MicroNet View Software  
DS 10.202 - VisiSat Configuration Tool

#### Multi-Lingual Instructions

MLI 10.050 - Installation Instructions  
MLI 10.310 - MN-DK Installation



## INSTALLATION

### Inspection

Inspect carton for damage. If damaged, notify carrier immediately. Inspect Touch Screen for damage. Return damaged products.

### Requirements

(These items are not provided)

- Installer must be an experienced technician
- Job wiring diagrams
- Tools:
  - Saw for panel mounting
  - Drill and bits
  - Digital Volt- $\Omega$  meter (DVM)
  - Static protection wrist strap.
- If the Touch Screen is not connected directly to an MN550 or MN650 via a ribbon cable, an EN 61558 power transformer is required, as described opposite.
- Three No. 10 self-starting screws for wall mounting or 35mm DIN rail for mounting.
- Terminators (If MicroNet LONWORKS network is used):
  - One LON<sup>®</sup>-TERM1 terminator required for free topologies.
  - Two LON-TERM2 terminators required for bus topologies.

### Precautions

#### General

- Follow Static precautions when installing this equipment.
- Use copper conductors that are suitable for 75°C (167°F).
- Make all connections according to electrical wiring diagram, national and local electrical codes.

#### Static Precautions

Static charges damage electronic components. The microprocessor and associated circuitry are extremely sensitive to static discharge. Use the following precautions when installing, servicing or operating the system:

- Work in a static-free area.
- Discharge static electricity by touching a known, securely grounded object.
- Use a wrist strap connected to earth ground when handling the Touch Screen's printed circuit board.
- Direct static discharge on the Touch Screen may cause it to lock out. If this occurs, reset the unit by switching the Touch Screen power on and off.

#### European Community Directives

This equipment meets all requirements of European Community Directives for Low Voltage (72/23/EEC), General Safety (92/59/EEC), and Electromagnetic Compatibility (89/336/EEC).

#### Federal Communications Commission (FCC)

This equipment has been tested and found to comply with the limits for a Class A digital device, pursuant to Part 15 of the FCC Rules. These limits are designed to provide reasonable protection against harmful interference when the equipment is operated in a commercial environment. This equipment generates, uses, and can radiate radio frequency energy and if not installed and used in accordance with the instruction manual, may cause harmful interference to radio communications. Operation of this equipment in a residential area is likely to cause harmful interference, in which case the user will be required to correct the interference at his own expense.

#### Canadian Department of Communications (DOC)

This digital apparatus does not exceed the Class A limits for radio noise emissions from digital apparatus set out in the radio interference regulations of the Canadian Department of Communications.

### Power Supply Wiring Precautions

- This product contains a non-isolated half-wave rectifier power supply and must not be powered by transformers used to power other devices containing non-isolated full-wave rectifier power supplies. Refer to DS 10.250, *EN-206, Guidelines for Powering Multiple Full-Wave and Half-Wave Rectifier Devices from a Common Transformer* for detailed information.
- The 24Vac 50/60Hz supply must comply with EN 61558 and be capable of supplying at least 8VA. Class 2 circuits must not intermix with Class 1 circuits. The supply to the transformer must have a breaker or disconnect. If the Touch Screen is mounted on a standalone NCP MN550 or MN650 controller, the controller transformer must be upgraded to supply an extra 8VA for the Touch Screen.
- The transformer frame and Touch Screen 0V terminal must be connected to earth; see page 6.

## Location

The Touch Screen is suitable for indoor use only. When selecting a mounting location, make certain the following conditions are met:

- Do not install where excessive moisture, corrosive fumes, vibration, or explosive vapours are present.
- Do not install near large contactors, electrical machinery, or welding equipment.
- Allow 150mm clearance from contactors, switches, and associated cabling.

Locate where ambient temperatures do not exceed 40°C or fall below 0°C and relative humidity does not exceed 95% or fall below 5%, non-condensing.

## Mounting

### Panel Mounting (TSP Models)

1. Select mounting location.
2. Draw cut out dimensions onto panel.
3. Carefully cut around outline on panel. Remove any burrs and smooth rough edges.
4. Remove four screws on Touch Screen back cover.
5. Remove back cover.
6. Go to Battery Setup section and enable battery.
7. Place Touch Screen in panel opening.
8. While holding Touch Screen in place, re-install back cover.
9. Re-install four screws on back cover and tighten.
10. Check for a secure fit between back cover, panel and front of Touch Screen.

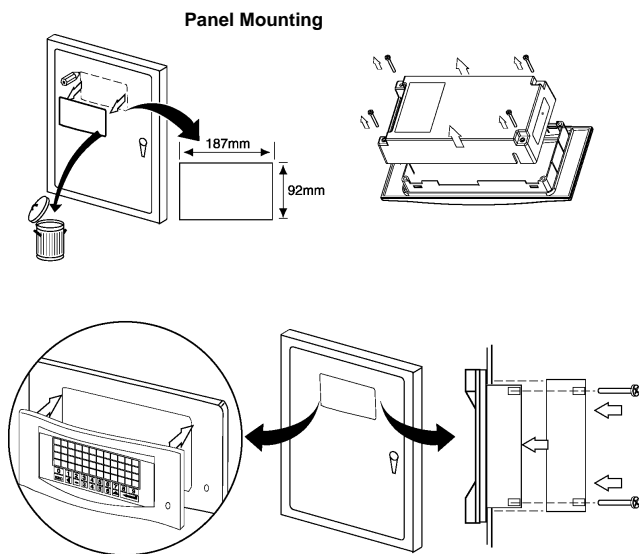

## Wall or DIN Rail Mounting

For Wall or DIN rail mounting, a separate Wall Mounting Kit (MN-DK) is needed.

1. Select mounting location. Allow minimum 150mm clearance around Touch Screen.
2. Do the following to mount Touch Screen on a wall:
  - a. Loosen two screws securing terminal cover to MN-DK and remove cover.
  - b. If not already fitted, press the wall mounting clip into the back of the MN-DK.
  - c. Lift wall mounting bracket clip. (Located on top back of MN-DK.)
  - d. Using a No. 10 self-starting screw, install top screw.
  - e. Lift and level MN-DK.
  - f. Using two No. 10 self-starting screws, install bottom screws.
  - g. Install and fix Touch Screen to MN-DK.
  - h. Re-install terminal cover. (May be left off until wiring is completed.)
3. Do the following to mount Touch Screen on a DIN rail:
  - a. Loosen two screws securing terminal cover to MN-DK and remove cover.
  - b. While pulling down on DIN rail locking bracket, snap MN-DK on a 35mm DIN mounting rail.
  - c. Release DIN rail locking bracket.
  - d. Install and fix Touch Screen to MN-DK.
  - e. Re-install terminal cover. (May be left off until wiring is completed.)

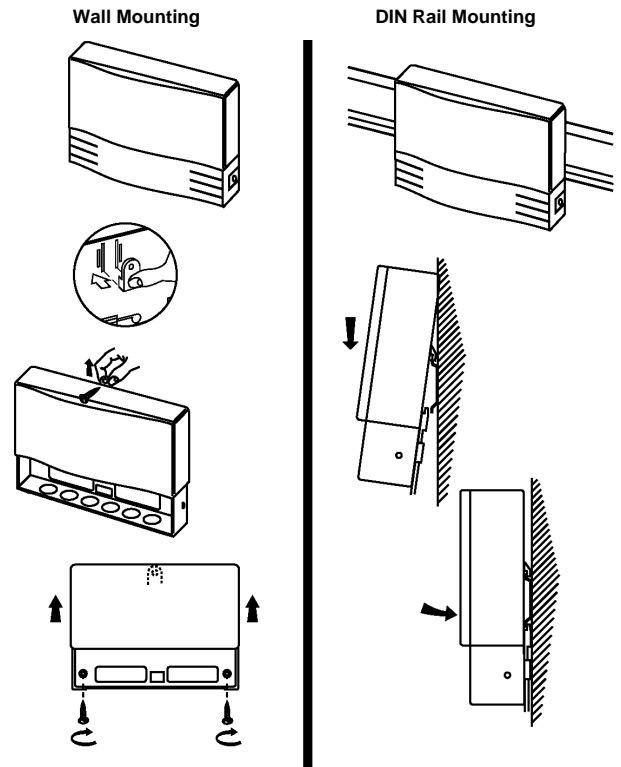

### Mounting the Touch Screen (MN50-TS-NCP only) in an NCP MN550/650 Controller



**WARNING - ELECTRICAL SHOCK HAZARD.**  
**THE MN550 CAN CONTAIN MAINS VOLTAGES.**  
**DISCONNECT THE DIGITAL OUTPUTS BEFORE**  
**REMOVING THE COVER OF THE CONTROLLER.**

1. Remove the two screws holding the large front panel of the controller in place.
2. Remove the controller front panel.
3. Remove four screws on Touch Screen back cover.
4. Remove the Touch Screen back cover.
5. Connect the ribbon cable from the Touch Screen to the connector on the controller PCB.
6. Go to Battery Setup section and enable the Touch Screen battery.
7. Secure the Touch Screen to the top of the controller using the screws from the controller front panel (you will need to punch through the screw positions on the Touch Screen front panel).

## Terminal Connections

Touch Screen - Wall Mount

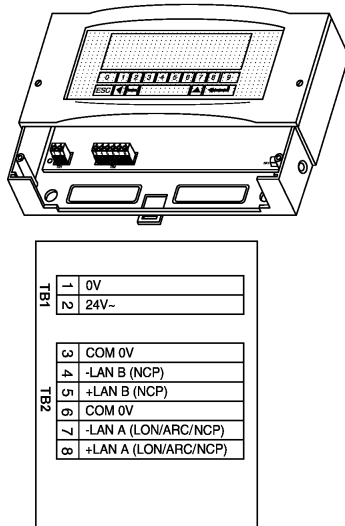

Touch Screen - Panel Mount

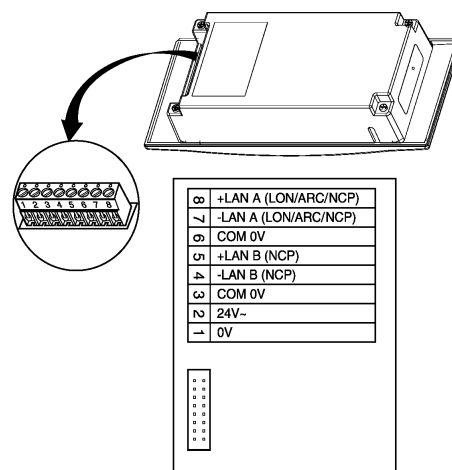

Terminals accept one 1mm<sup>2</sup> wire

## Network Wiring



**WARNING - ELECTRICAL SHOCK HAZARD.**  
**THE MN350 AND MN550 CAN CONTAIN MAINS VOLTAGES. DISCONNECT ALL MAINS VOLTAGES WHILE THE COVER OF THE CONTROLLER IS REMOVED.**

### Introduction

Network wiring includes a connection between the Touch Screen and a MicroNet controller network. Depending on the specific Touch Screen model, one of three network types can be used:

- NCP networks
- FTT LONWORKS network
- ARCNET network

Note that termination of cable screens can be critical to performance, particularly in an ARCNET network.

Network wiring must not be routed with power wiring.

Network wire pairs must be dedicated to MicroNet network communications. They cannot be part of an active, bundled telephone trunk.

If network cable is installed in areas of high RFI/EMI, the cable must be in conduit.

Refer to the *MicroNet System Engineering Guide* for further guidance, including network topologies, wiring, network lengths, termination and cable types.

### NCP/ARCNET Screens

NCP and ARCNET networks require screened cable. Connect the screen to earth at one end of the cable only. If earthing at a Touch Screen, connect to terminal 1. Keep wires emerging from screened cable as short as possible.

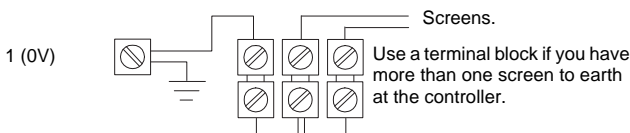

Note: Satisfactory NCP or ARCNET communications relies on the earth (0V) potential varying no more than 7V between any two devices in the network (e.g. between an MN MI and any controller, or between any two controllers). If this is not the case, you need to introduce NCP repeaters or ARCNET routers and connect the network screens as given in the *MicroNet System Engineering Guide*.

### LONWORKS Touch Screen Network Wiring (MNL-TS-100)

LONWORKS Touch Screens may be connected to any FTT LONWORKS wiring segment. The internal MNL-C LON card uses the FTT-10A transceiver.

LONWORKS wiring segments using FTT-10A nodes can also include LPT-10 nodes. Before adding MicroNet LONWORKS devices to an existing LPT-10 network, test for LPT level voltage (48Vdc) across the two network conductors. If this voltage is present, locate and temporarily remove the 48Vdc power before connecting new wiring and nodes to the segment.

Recommended cable for most FTT LONWORKS networks is Level 4 plenum-rated 0.65mm (22AWG), as defined by the National Electrical Manufacturers Association (NEMA), but read the following note. Screened cable is optional, depending on electrical noise levels. If screened cable is used, it must be grounded (through a 470kΩ resistor and a 0.1μF capacitor connected in parallel) **at one end only**.

Note: Further information is provided in the *MicroNet System Engineering Guide*. It is also important to refer to the LONWORKS Wiring Guidelines ([www.echelon.com/Products/technical/bulletins.asp](http://www.echelon.com/Products/technical/bulletins.asp)) for the very latest information about LONWORKS cable types, lengths, etc.

1. Review the Precautions section.
2. Connect two twisted wires of the FTT network cable to terminals 7 and 8 of Touch Screen as shown below. Polarity makes no difference.

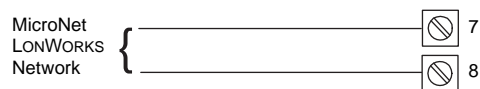

3. Depending on topology chosen for the FTT segment, attach other controllers and Touch Screens freely using multiple wiring trees and stars (free topology), or connect only in a device-to-device fashion (bus topology).
4. Fit the terminator(s):
  - If attaching the Touch Screen to an FTT-10A free topology wiring segment, fit one LON-TERM1 terminator to any node on the segment.
  - If attaching to an FTT-10A bus topology wiring segment, use two LON-TERM2 terminators, one at each end of the segment.

Note: Any wiring segment that includes LPT nodes should use the Echelon®-approved 1.3mm (16 AWG) wire, a free-topology architecture (singly terminated), and a termination designed specifically for use with the LPT-10 (LPT-10 Link Power Interface, with jumper at '1 CPLR' setting).

### NCP Network Wiring (MN50-TS-NCP)

A Touch Screen can connect to the 'main LAN' of an NCP network and creates a network sub-LAN, to which other NCP controllers can connect. An NCP Touch Screen can be used to display and change data only from the controllers on its sub-LAN.

Recommended cable for NCP networks is Belden 9502 dual twisted-pair screened cable. However, Belden 8762 (single twisted pair cable) can be used providing that the wiring precautions shown in the *MicroNet System Engineering Guide* are followed.

Before wiring the Touch Screen fit the two jumpers to the links shown in the following diagram.

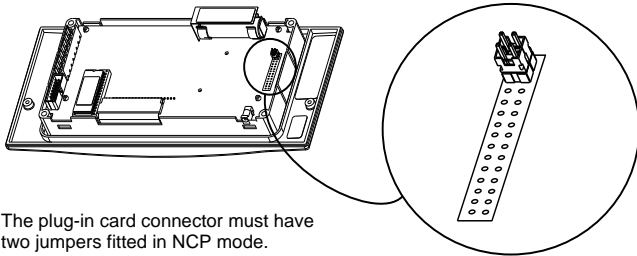

The plug-in card connector must have two jumpers fitted in NCP mode.

Note: If the Touch Screen is mounted in an NCP MN550 or MN650 controller, the NCP main LAN and sub-LAN must be connected to the controller's terminals, not to the Touch Screen's terminals. Refer to the MN550 data sheet (DS 10.153A) or MN650 data sheet (DS 10.154A) for connection details.

If the Touch Screen is not mounted in an NCP MN550 or 650 controller, connect the NCP network as follows.

1. Review Precautions section.
2. Connect the network to the Touch Screen, as shown in the following diagram. **Observe correct polarity.**
3. Ground the NCP wiring screen **at one end of the cable only.**

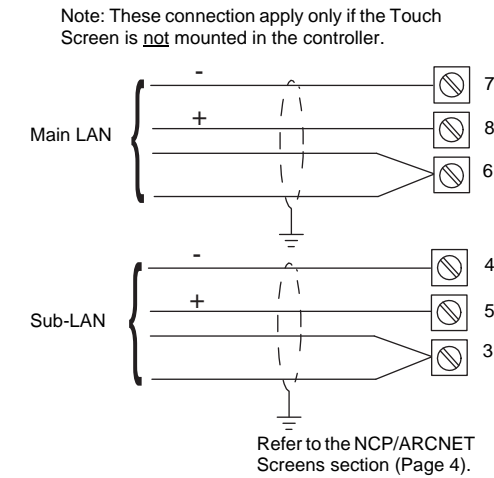

### ARCNET Network Wiring (MN50-TS-ARC)

Touch Screens may be networked to either a 'main LAN' under an MN MI (MNN-MI-100) or to a 'sub-LAN' under an ARCNET router.

For performance reasons when transferring network variables between controllers and Touch Screens, the main LAN should have only ARCNET routers connected to it, unless there are no sub-LANs.

An ARCNET Touch Screen can be used to display and change data from any controller on the network, including controllers on different sub-LANs.

Recommended cable for ARCNET networks is Belden 9502 dual twisted-pair screened cable.

1. Review Precautions section.
2. Connect the network to the Touch Screen, as shown in the following diagram. **Observe correct polarity.**
3. Connect the Touch Screen with other ARCNET devices in a device-to-device fashion. Do not use wiring trees or stubs.
4. Ground the ARCNET wiring screen **at one end of the cable only.**
5. The devices *at each end* of the network must be biased and terminated by fitting jumpers to links LK1, LK2 and LK11 on the ARCNET card. If the Touch Screen is not at one end, leave the links unset.

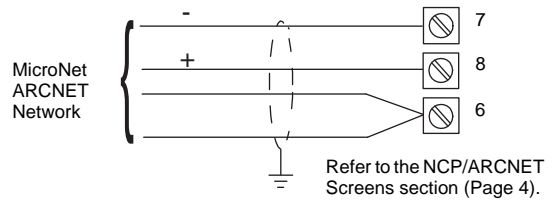

ARCNET termination and biasing links

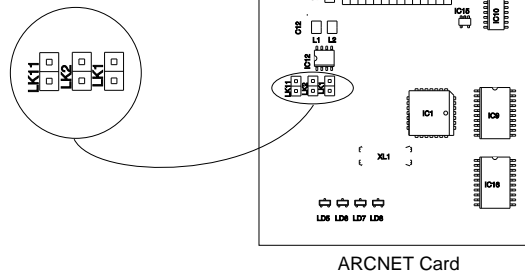

### Battery Setup

The unit is shipped with the battery disabled to preserve battery life. To enable battery, do the following:

1. Remove battery.
2. Remove protective strip from battery.

#### REMOVING PROTECTIVE STRIP FROM BATTERY ON WALL UNIT

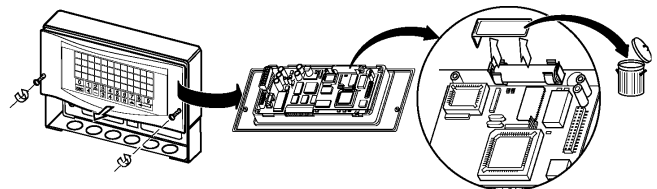

#### REMOVING PROTECTIVE STRIP FROM BATTERY ON PANEL MOUNT UNIT

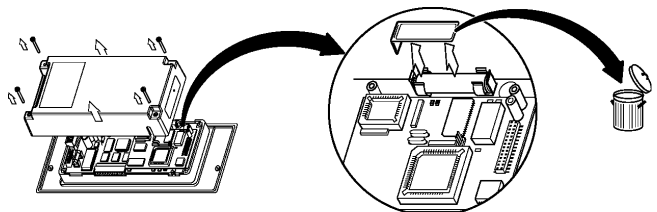

3. Re-install battery. (Make certain polarity is correct.)
4. Make certain battery is fully seated in battery holder.

## Power Supply Wiring

Note: If the Touch Screen is connected directly to an MN550 or MN650 via a ribbon cable, a connection to a 24Vac power supply is not required. However, the controller transformer must be upgraded to supply an extra 8VA for the Touch Screen.

Notes:

1. This product contains a non-isolated half-wave rectifier power supply and must not be powered by transformers used to power other devices containing non-isolated full-wave rectifier power supplies. If multiple devices are powered from the same transformer, verify that the transformer is properly sized to power all equipment simultaneously and all devices contain the same type of rectifier power supplies or internal isolation. Also verify that correct polarity has been maintained between all connected devices. Refer to DS 10.250, *EN-206, Guidelines for Powering Multiple Full-Wave and Half-Wave Rectifier Devices from a Common Transformer* for detailed information.
2. Install wiring according to job wiring diagrams and local electrical codes.
3. The wire gauge used must be consistent with load current rating.

### 24Vac Power Wiring

1. Review Precautions section.
2. Ensure that the Touch Screen 0V terminal is connected to Earth **before** connecting the power wiring to the Touch Screen.
3. Connect power ground wiring to terminal 1.
4. Connect power 24Vac wiring to terminal 2.

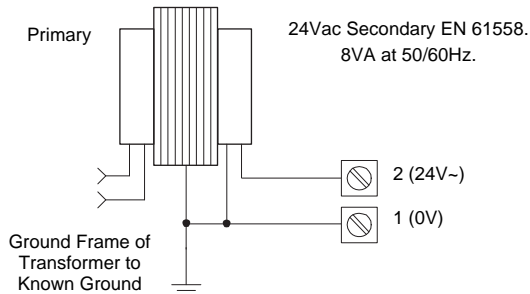

## CHECKOUT

### Mechanical Hardware Checkout



1. Verify network wiring between Touch Screen and other devices is installed according to job wiring diagram and national and local electrical codes.
2. Verify 24Vac power is provided from a power transformer conforming to EN 61558 and wiring is installed according to job wiring diagrams and with national and local electrical codes.

### Preliminary Setup Procedure

Note: See the Touch Screen User's Guide for full details.

Energise Touch Screen and verify logo screen appears.

#### Accessing the System Screen

1. Press ENTER twice from the logo screen. A password entry box appears.
2. Using keys on Touch Screen key pad, type in 1024. Use BACKSPACE  to delete any incorrect entries. Press ESC to cancel input.
3. Press ENTER.
4. Press  (NEXT SCREEN) until the System Screen is displayed:



## Displaying the Maintenance Screen

1. From System screen, press the Wrench icon, then ENTER. The Maintenance Screen appears. For example:

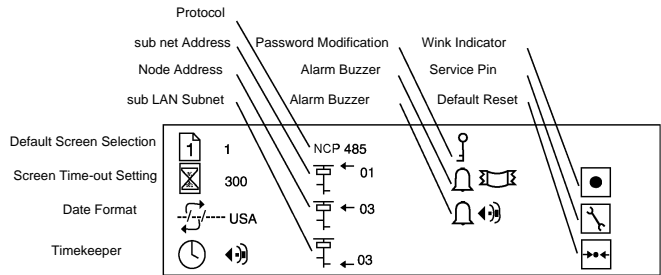

### Choosing the Date Format

Note: There are two date formats available in the Touch Screen. The 'UK' version is set up as DD/MM/YYYY with a 24 hour clock. The 'USA' version uses MM/DD/YYYY and is displayed in 12 hour format. The format chosen is displayed next to the icon on the Maintenance Screen. For example:



1. On the Maintenance Screen, press the Date Format Icon.
2. Press ENTER. The date format toggles to other format.
3. Press ESC to return to the System screen.

### Setting the Time

Note: The Touch Screen time and date is automatically updated from MN MI (if connected).

1. Select the Clock icon on the System Screen, then press ENTER. The icons to set a time value, then press ESC to return to the Time screen appears. For example:

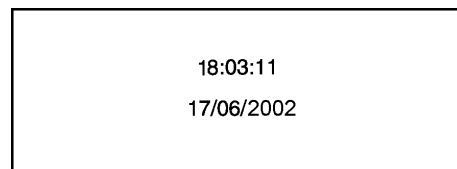

2. Touch the value to change, then press ENTER.
3. To set a time value, use the displayed scroll icons, then press ESC to return to the Time and Date screen. To set a date value, type the new value in the entry box displayed, then press ENTER.
4. Repeat the procedure on each field until the correct time and date are displayed.
5. Press ESC to return to the System Screen.

## NCP/ARCNET Touch Screen Addressing

Each controller or Touch Screen on the same NCP or ARCNET LAN needs a unique node address. The node address of two devices can be the same if they are on different LANs; that is, separated by a router in an ARCNET network (Touch Screens are allowed only on the main LAN of an NCP network).

For an NCP Touch Screen, the subnet address of the controllers on the Touch Screen's sub-LAN is the same as the Touch Screen's node address.

To set the Touch Screen's node address:

1. From the System screen, touch the Wrench icon and press ENTER. The Maintenance Screen is displayed.
2. On the Maintenance screen, select the Node Address Icon, then press ENTER.
3. An entry box appears. Type in the new address (numbers only), then press ENTER.
4. The sub-LAN address automatically follows the node address.

Note: The Node address is the only one that can be changed from the Touch Screen.



Sub net Address: This is the subnet address of the Touch Screen (for an NCP network, always 1).



Node Address: The node address of the Touch Screen.



Sub LAN Address: The subnet address of the sub-LAN created by an NCP Touch Screen. (Not relevant for ARCNET.)

## LONWORKS Touch Screen Addressing

LONWORKS Touch Screens are addressed directly using a Neuron<sup>®</sup> ID (LONWORKS serial number). Each LON card has a unique Neuron ID, which is encoded during manufacture.

When addressing a LONWORKS Touch Screen in VisiSat, pressing the Service Pin on the LON card broadcasts the Neuron ID, which VisiSat picks up automatically (see the *VisiSat Engineering Guide* for further information).

Service pin messages can be sent from a Touch Screen as many times as necessary.

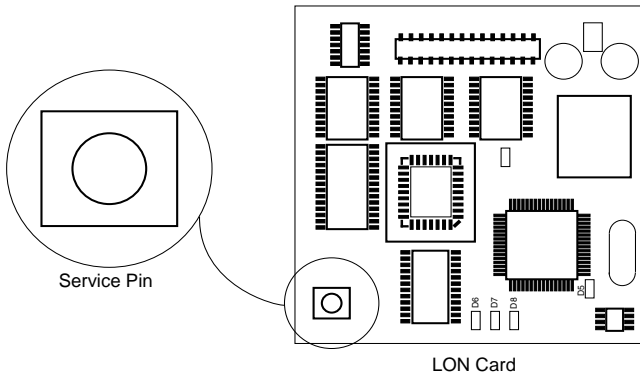

Note: The Touch Screen Neuron ID is also printed on the factory barcode labels attached to the LON card. One of the labels remains on the LON card permanently, the other label can be placed on a job site's node list plan. The Neuron ID can be manually entered in VisiSat Configuration Tool to identify the Touch Screen, as an alternative to using the Service Pin method of addressing.

## COMMUNICATIONS CHECKOUT

### ARCNET Card LEDs

LEDs LD5 to LD8 have the following meanings:

LD5 (Green, 'Online' LED)	ON when node is online (normal use). OFF when node is off line.
LD6 (Red, 'Error' LED)	OFF when no network errors. ON when duplicate node on network, or if network is reconfiguring. Flickering when bad data packet received.
LD7 (Yellow 'Rx' LED)	ON when data packet received.
LD8 (Yellow 'Tx' LED)	ON when data packets transmitted.

Refer to the *MicroNet System Engineering Guide* for further information about the ARCNET LEDs.

### LON Card LEDs

The LEDs on the LON card have the following meanings.

D8 (Green)	ON when data is being transmitted from the LON card to the Touch Screen.
D7 (Green)	ON when data is being transmitted from the Touch Screen to the LON card.
D5 (Yellow)	OFF in normal working mode. ON when SNVTs are being created by VisiSat, or if not yet configured by third-party LonMaker™ binding tool. If otherwise ON, the card is probably unserviceable. Flashes at 0.5Hz when LonMaker application has been deleted from the third-party application (i.e. no network addressing information).
D6	Not used.

Refer to the *MicroNet System Engineering Guide* for further information about the LON card.

## SERVICING

### Caution

**Direct static discharge onto the Touch Screen unit may cause it to lock out. If this should occur, reset the unit by switching the Touch Screen power off and on.**

Components within a Touch Screen can not be field repaired. If there is a problem, carry out the following procedure before contacting your local sales office.

1. Make sure Touch Screen is connected and communicating to desired devices.
2. Record precise hardware setup indicating the following:
  - Touch Screen firmware version number.
  - Information regarding the Version number and build number of the VisiSat Configuration Tool (see 'About VisiSat' option in the VisiSat Tool Help menu).
  - A complete description of difficulties encountered.

### Fuse Replacement

A fuse provides overcurrent protection for the Touch Screen. Following static precautions, do the following to check and replace fuse:

1. Turn OFF power to Touch Screen.
2. Remove Touch Screen cover.
3. Remove fuse.
4. Check continuity across fuse.
5. If fuse is faulty, replace fuse with same type and rating (2A anti-surge).
6. Re-install cover.
7. Turn ON power to Touch Screen.

### FUSE LOCATION

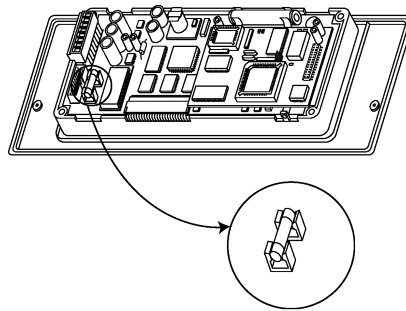

### Battery Replacement

#### WARNING -

**THE PCB CONTAINS A LITHIUM CHLORIDE BATTERY WHICH IS COMPLETELY SAFE WHILST IN NORMAL USE. THE BATTERY MUST BE DISPOSED OF IN ACCORDANCE WITH LOCAL WASTE REGULATIONS.**

Should there be a power failure, the clock and RAM are protected with a battery-backup. Do the following to check and replace battery (removing the battery does not affect the Touch Screen's configuration):

1. Turn OFF power.
2. Remove cover.
3. Remove battery and check battery.
4. If battery is faulty, replace battery with same type and rating. (TAC Satchwell part number E17-129, 3.6V AA Non-rechargeable Lithium)
5. Re-install cover.
6. Turn ON power to Touch Screen.
7. Dispose of battery properly.

### BATTERY LOCATION

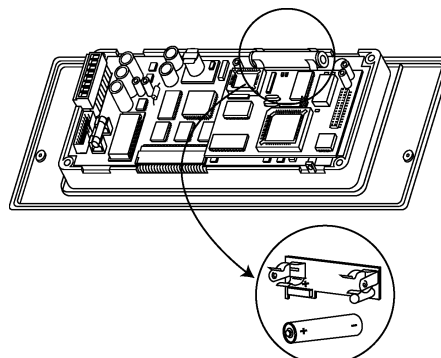

## DIMENSION DRAWING

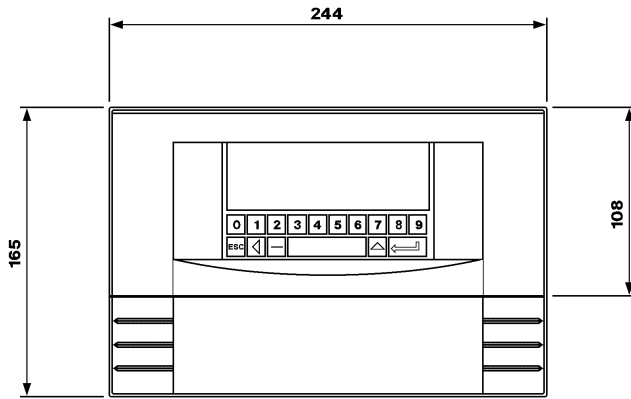

Dimensions in mm

Weights:

MN-TS-NCP	567.3g
MN-TS-ARC	585.6g
MNL-TS-100	598.4g

### WARNING -

THE RTC BOARD CONTAINS A LITHIUM CHLORIDE BATTERY WHICH IS COMPLETELY SAFE WHILST IN NORMAL USE. THE BATTERY MUST BE DISPOSED OF IN ACCORDANCE WITH LOCAL WASTE REGULATIONS.

- Do not apply any voltages until a qualified technician has checked the system and the commissioning procedures have been completed.
- This is a 24Vac device. Do not exceed rated voltage. Local wiring regulations and usual safety precautions apply.
- 24Vac must be supplied by a transformer conforming to EN 61558.
- If any equipment covers have to be removed during the installation of this equipment, ensure that they are refitted after installation to comply with UL and CE safety requirements.
- Do not exceed the maximum ambient temperature.
- Interference with parts under sealed covers invalidates guarantee.
- The design and performance of TAC Satchwell equipment is subject to improvement and therefore liable to alteration without notice.
- Information is given for guidance only and TAC Satchwell does not accept responsibility for the selection or installation of its products unless information is given by the Company in writing relating to a specific application.
- A periodic system and tuning check of the control system is recommended.

Copyright © 2007, TAC AB  
All brand names, trademarks and registered trademarks are the property of their respective owners. Information contained within this document is subject to change without notice. All rights reserved.

DS 10.050A 01/07



### TAC Headquarters

Malmö, Sweden  
+46 40 38 68 50

### Satchwell Helpline

+44 (0) 1753 611000  
satchwell.info@uk.tac.com

[www.tac.com](http://www.tac.com)

