

WIRING AND COMMISSIONING INFORMATION FOR SATCHWELL MICRONET LCD DISPLAY

APPLICATION

Order Types:

- MN50-LCD - MicroNet LCD - Controller or Wall Mount
- MNN-LCDP-100 - MicroNet LCD - Panel Mount

The MicroNet LCD is a menu driven LCD display that allows a user to monitor and configure parameters of an MN350, MN450, MN550 or an MN650 controller. The LCD is fully programmable using the VisiSat Configuration Tool.

The LCD can be used to interrogate and alter temperature inputs, plant conditions, plant overrides, time and holiday schedules that reside on MicroNet controllers. Up to 246 lines of data can be displayed.

The MN50-LCDP can be mounted on a control panel and connected to a controller. The MN50-LCD and MN50-LCDP models can be housed in a wall mounting unit, remotely from the controller, and can also be mounted on an MN550 or an MN650 controller.

When the LCD is mounted remotely, it may be connected to an MN350-NCP, MN450-NCP, MN550-NCP or MN650-NCP controller operating in stand-alone mode. In addition, the LCD can be connected to an MN550-ARC or MN650-ARC (for ARCNET networks), MN550-XCOM or MN650-XCOM (for NCP networks) or an MN550-LON or MN650-LON (for LonWorks networks).

The LCD can be mounted on any MN550 or MN650 controller (except the LON variants) using the supplied ribbon cable.

The LCD features a built-in Real Time Clock (RTC), powered separately by a Lithium battery to provide time setting and synchronisation for a stand-alone controller. It can also be used for network time synchronisation across a LonWorks network.

The LCD configuration is saved on EEPROM, providing protection from power failure.

An LCD cannot be connected to an MN550 or MN650 controller that is fitted with a Touch Screen.

SPECIFICATION

Order Type	Description	Voltage
MN50-LCD	MicroNet NCP LCD - Wall/Controller Mount	24Vac, 50/60Hz
MN50-LCDP	MicroNet NCP LCD - Panel Mount	24Vac, 50/60Hz



Data Sheets

DS 10.060 - LCD
DS 10.201 - MicroNet View Software
DS 10.202 - VisiSat Configuration Tool

Multi-Lingual Instructions

MLI 10.060 - Installation Instructions
MLI 10.300 - MNN-C and MNA-C Installation
MLI 10.310 - MN-DK Installation



INSTALLATION

Inspection

Inspect carton for damage. If damaged, notify carrier immediately. Inspect LCD for damage. Return damaged products.

Requirements

(These items are not provided)

- Installer must be an experienced technician
- Job wiring diagrams
- Tools:
 - Saw for panel mounting
 - Drill and bits
 - Digital Volt- Ω meter (DVM)
 - Static protection wrist strap.
- If the LCD is not connected directly to an MN550 or MN650 via a ribbon cable, an EN 61558 power transformer is required, as described opposite.
- Three No. 10 self-starting screws for wall mounting or 35mm DIN rail for mounting.

Precautions

General

- Follow Static precautions when installing this equipment.
- Use copper conductors that are suitable for 75°C.
- Make all connections according to electrical wiring diagram, national and local electrical codes.

Static Precautions

Static charges damage electronic components. The microprocessor and associated circuitry are extremely sensitive to static discharge. Use the following precautions when installing, servicing or operating the system:

- Work in a static-free area.
- Discharge static electricity by touching a known, securely grounded object.
- Use a wrist strap connected to earth ground when handling the LCD's printed circuit board.
- Direct static discharge on the LCD may cause it to lock out. If this occurs, reset the unit by switching the LCD power on and off.

European Community Directives

This equipment meets all requirements of European Community Directives for Low Voltage (72/23/EEC), General Safety (92/59/EEC), and Electromagnetic Compatibility (89/336/EEC).

Federal Communications Commission (FCC)

This equipment has been tested and found to comply with the limits for a Class A digital device, pursuant to Part 15 of the FCC Rules. These limits are designed to provide reasonable protection against harmful interference when the equipment is operated in a commercial environment. This equipment generates, uses, and can radiate radio frequency energy and if not installed and used in accordance with the instruction manual, may cause harmful interference to radio communications. Operation of this equipment in a residential area is likely to cause harmful interference, in which case the user will be required to correct the interference at his own expense.

Canadian Department of Communications (DOC)

This digital apparatus does not exceed the Class A limits for radio noise emissions from digital apparatus set out in the radio interference regulations of the Canadian Department of Communications.

Power Supply Wiring Precautions

- This product contains a non-isolated half-wave rectifier power supply and must not be powered by transformers used to power other devices containing non-isolated full-wave rectifier power supplies. Refer to DS 10.250, *EN-206, Guidelines for Powering Multiple Full-Wave and Half-Wave Rectifier Devices from a Common Transformer* for detailed information.
- The 24Vac 50/60Hz supply must comply with EN 61558 and be capable of supplying at least 4VA. Class 2 circuits must not intermix with Class 1 circuits. The supply to the transformer must have a breaker or disconnect. If the LCD is mounted on a stand-alone NCP MN550 or MN650 controller, the controller transformer must be upgraded to supply an extra 4VA for the LCD.
- The transformer frame and LCD GND terminal must be connected to earth; see page 5.

Location

The LCD is suitable for indoor use only. When selecting a mounting location, make certain the following conditions are met:

- Do not install where excessive moisture, corrosive fumes, vibration, or explosive vapours are present.
- Do not install near large contactors, electrical machinery, or welding equipment.
- Allow 150mm clearance from contactors, switches, and associated cabling.

Locate where ambient temperatures do not exceed 50°C or fall below 0°C and relative humidity does not exceed 95% or fall below 5%, non-condensing.

Mounting

Panel Mounting (LCDP Models)

1. Select mounting location.
2. Draw cut out dimensions onto panel.
3. Carefully cut around outline on panel. Remove any burrs and smooth rough edges.
4. Remove four screws on LCD back cover.
5. Remove back cover.
6. Go to Battery Setup section and enable battery.
7. Place LCD in panel opening.
8. While holding LCD in place, re-install back cover.
9. Re-install four screws on back cover and tighten.
10. Check for a secure fit between back cover, panel and front of LCD.

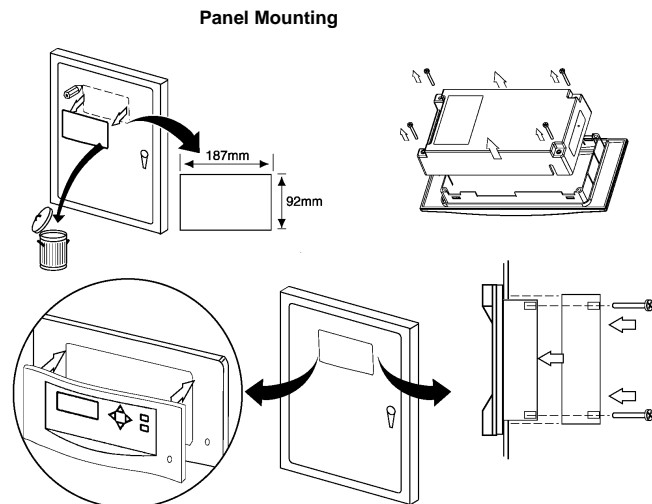

Wall or DIN Rail Mounting

For Wall or DIN rail mounting, a separate Wall Mounting Kit (MN-DK) is needed.

1. Select mounting location. Allow minimum 150mm clearance around LCD.
2. Do the following to mount LCD on a wall:
 - a. Loosen two screws securing terminal cover to MN -DK and remove cover.
 - b. If not already fitted, press the wall mounting clip into the back of the MN-DK.
 - c. Lift wall mounting bracket clip. (Located on top back of MN-DK.)
 - d. Using a No. 10 self-starting screw, install top screw.
 - e. Lift and level MN-DK.
 - f. Using two No. 10 self-starting screws, install bottom screws.
 - g. Install and fix LCD to MN-DK.
 - h. Re-install terminal cover. (May be left off until wiring is completed.)
3. Do the following to mount LCD on a DIN rail:
 - a. Loosen two screws securing terminal cover to MN-DK and remove cover.
 - b. While pulling down on DIN rail locking bracket, snap MN-DK on a 35mm DIN mounting rail.
 - c. Release DIN rail locking bracket.
 - d. Install and fix LCD to MN -DK.
 - e. Re-install terminal cover. (May be left off until wiring is completed).

Wall Mounting

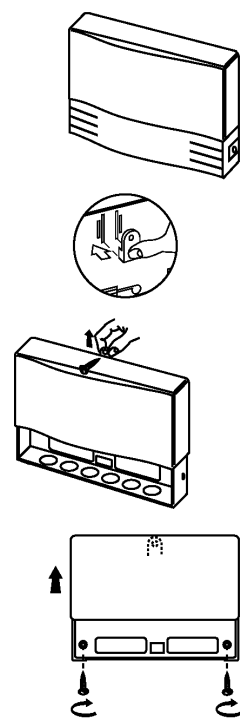

DIN Rail Mounting

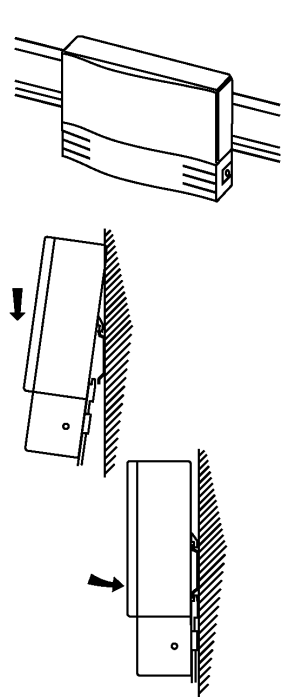

Mounting the LCD in a MN550/650 Controller



WARNING - ELECTRICAL SHOCK HAZARD.
THE MN550 CAN CONTAIN MAINS VOLTAGES.
DISCONNECT THE DIGITAL OUTPUTS BEFORE
REMOVING THE COVER OF THE CONTROLLER.

1. Remove the two screws holding the large front panel of the controller in place.
2. Remove the controller front panel.
3. Remove four screws on LCD back cover.
4. Remove the LCD back cover.
5. Connect the ribbon cable from the LCD to the connector on the controller PCB.
6. Go to Battery Setup section and enable the LCD battery.
7. Secure the LCD to the top of the controller using the screws from the controller front panel (you will need to punch through the screw positions on the LCD front panel).

Terminal Connections

LCD - Wall Mount

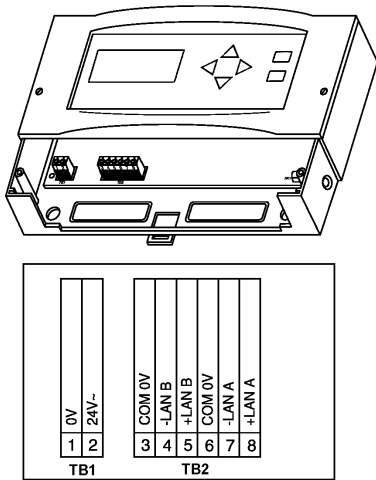

LCD - Panel Mount

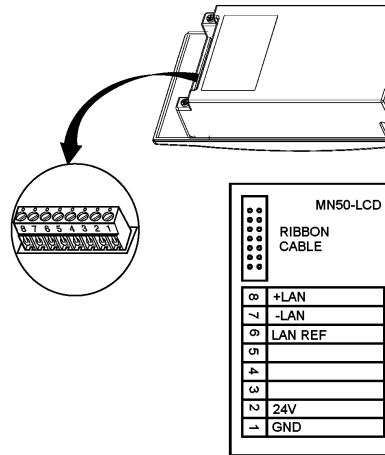

Terminals accept one 1mm² wire

Connecting the LCD to a Controller

A connection is required between the LCD and its controller. There are two methods of making this connection:

- You can use a ribbon cable if the LCD is mounted in a stand-alone NCP MN550 or MN650 controller. You can also use the ribbon cable if connected to an Arcnet (ARC) or dual NCP (XCOM) version of the MN550 or MN650 controller. For details of how to make this connection and upload the LCD configuration, refer to the Commissioning section.
- You can use a separate cable between the LCD and the network connections on the controller. This method is described next.



WARNING - ELECTRICAL SHOCK HAZARD.
THE MN350 AND MN550 CAN CONTAIN MAINS VOLTAGES. DISCONNECT ALL MAINS VOLTAGES WHILE THE COVER OF THE CONTROLLER IS REMOVED.

Separate Connection to Controller

You can make the communications connection between the LCD and its controller using a separate Belden 8762 twisted-pair screened cable.

The cable must not be routed with power wiring, and if installed in areas of high RFI/EMI, the cable must be in conduit.

Note: Before making the following connections to a stand-alone NCP controller, connect an MN50-MI-NCP to the controller, then use VisiSat to download the LCD configuration to the controller. Once the download is complete, the LCD will automatically upload the configuration from a networked MN550 or MN650 (ARC, XCOM or LON). For stand-alone controllers, disconnect the MN50-MI-NCP and connect the LCD to complete the configuration upload to the LCD. Applying power to the LCD while pressing its "Down" key causes the LCD to upload its configuration from the controller, provided the LCD's Configuration Locked property is not set to Yes in VisiSat.

- Review Precautions section.
- Connect the LCD to the controller as shown in the following diagram. **Observe correct polarity.**
- Ground the wiring screen **at one end of the cable only.**

Controller terminals. Use the terminals as shown in the following table.

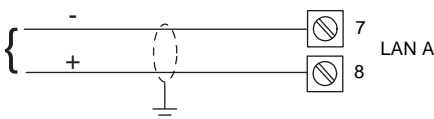

The following table specifies the terminals to use at the controller:

Controller Terminals	Controller
22(-) and 23(+)	Networked ^a or stand-alone MN550 controller
32(-) and 33(+)	Networked ^a or stand-alone MN650 controller
22(-) and 23(+)	Stand-alone NCP MN350 controller
13(-) and 14(+)	Stand-alone NCP MN450 controller

^a You can use the supplied ribbon cable instead of connecting to the controller terminals; see Page 3.

Commissioning

STAND-ALONE COMMISSIONING (MN350-NCP, MN450-NCP, MN550-NCP, MN650-NCP)

- Power down and disconnect the LCD and replace with an MN50-MI-NCP (or LIB485).
- Power up and download the LCD configuration from VisiSat to the controller.
- Power down and disconnect the MN50-MI-NCP (or LIB485) and replace with the LCD.
- Power up; the LCD will automatically upload the configuration.

NETWORK COMMISSIONING (MN550-XCOM, MN650-XCOM, MN550-ARC, MN650-ARC, MN550-LON & MN650-LON)

- Download the LCD configuration to the controller from VisiSat; once complete the LCD will automatically upload the configuration.

Battery Setup

The unit is shipped with the battery disabled to preserve battery life. To enable battery, do the following:

- Remove battery.
- Remove protective strip from battery.

REMOVING PROTECTIVE STRIP FROM BATTERY ON WALL UNIT

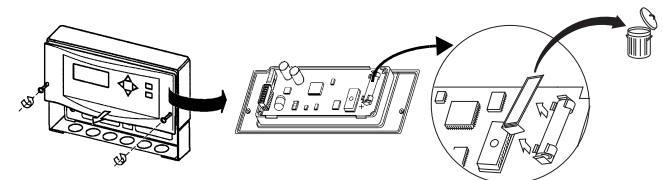

REMOVING PROTECTIVE STRIP FROM BATTERY ON PANEL MOUNT UNIT

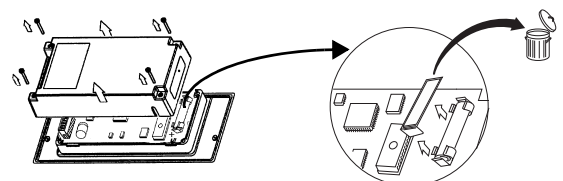

- Re-install battery. (Make certain polarity is correct.)
- Make certain battery is fully seated in battery holder.

Power Supply Wiring

Note: If the LCD is connected directly to an MN550 or MN650 via a ribbon cable, a connection to a 24Vac power supply is not required. However, the controller transformer must be upgraded to supply an extra 5VA for the LCD.

Notes:

1. This product contains a non-isolated half-wave rectifier power supply and must not be powered by transformers used to power other devices containing non-isolated full-wave rectifier power supplies. If multiple devices are powered from the same transformer, verify that the transformer is properly sized to power all equipment simultaneously and all devices contain the same type of rectifier power supplies or internal isolation. Also verify that correct polarity has been maintained between all connected devices. Refer to DS 10.250, *EN-206, Guidelines for Powering Multiple Full-Wave and Half-Wave Rectifier Devices from a Common Transformer* for detailed information.
2. Install wiring according to job wiring diagrams and local electrical codes.
3. The wire gauge used must be consistent with load current rating.

24Vac Power Wiring

1. Review Precautions section.
2. Ensure that the LCD 0V terminal is connected to Earth **before** connecting the power wiring to the LCD.
3. Connect power ground wiring to terminal 1.
4. Connect power 24Vac wiring to terminal 2.

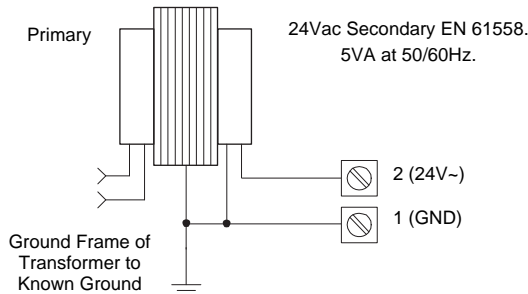

CHECKOUT

Mechanical Hardware Checkout

1. Verify wiring between LCD and controller is installed according to job wiring diagram and national and local electrical codes.
2. Verify 24Vac power is provided from a power transformer conforming to EN 61558 and wiring is installed according to job wiring diagrams and with national and local electrical codes.

LCD Controls

The LCD controls are as follows.

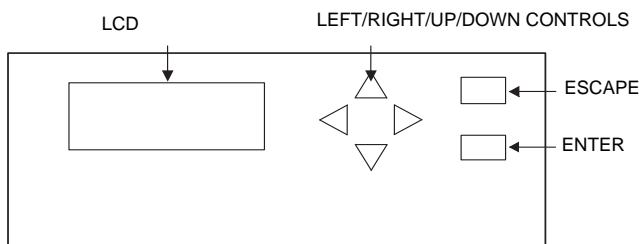

LCD Test Screen

Caution

This procedure will automatically erase the current configuration held on the LCD's controller unless the LCD 'Lock Configuration' property is set.

If you keep the Down key of the LCD pressed while applying power, the LCD performs a reset, and if the controller does not have an LCD configuration (perhaps because it has already been uploaded), the following screen is displayed:

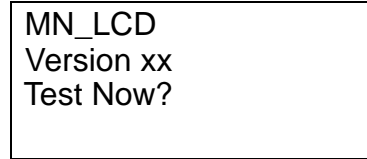

From this, you can determine the LCD firmware version number, test the unit, and try a manual upload (this should have no effect).

If you want to perform a test:

1. Use the Up/Down key to select Test Now, then press Enter.
2. Enter a passnumber of 1234. Use the Up/Down keys to select each digit of the passnumber, followed by the Right key to move to the next digit. Press Enter when all four digits have been selected.
3. Press each key. You should see the name of the key pressed on the display.
4. Press Enter to test the display. Each pixel should be lit.
5. Press Enter to see the results of the controller communications, EEPROM and RTC test. The controller type should be displayed next to "Unit". "! SAVED" should be displayed next to "RTC CAL".
6. Press Esc to return to the menu.

SERVICING

Caution

Direct static discharge onto the LCD unit may cause it to lock out. If this should occur, reset the unit by switching the LCD power off and on.

Components within a LCD can not be field repaired. If there is a problem, carry out the following procedure before contacting your local sales office.

1. Make sure LCD is connected and communicating to desired devices.
2. Record precise hardware setup indicating the following:
 - LCD firmware version number.
 - Information regarding the Version number and build number of the VisiSat Configuration Tool (see 'About VisiSat' option in the VisiSat Tool Help menu).
 - A complete description of difficulties encountered.

Fuse Replacement

A fuse provides overcurrent protection for the LCD. Following static precautions, do the following to check and replace fuse:

1. Turn OFF power to LCD.
2. Remove LCD cover.
3. Remove fuse.
4. Check continuity across fuse.
5. If fuse is faulty, replace fuse with same type and rating (1A Nano Slo-Blo manufactured by Littelfuse).
6. Re-install cover.
7. Turn ON power to LCD.

FUSE LOCATION

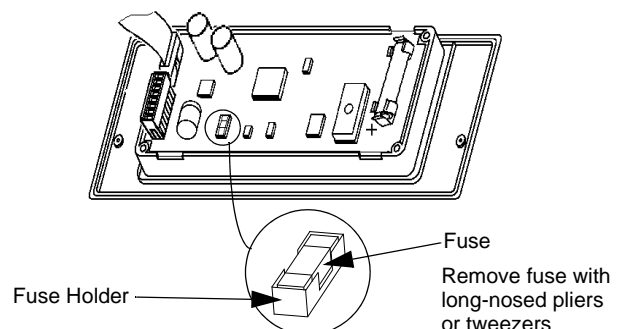

Battery Replacement

WARNING -

THE PCB CONTAINS A LITHIUM CHLORIDE BATTERY WHICH IS COMPLETELY SAFE WHILST IN NORMAL USE. THE BATTERY MUST BE DISPOSED OF IN ACCORDANCE WITH LOCAL WASTE REGULATIONS.

Should there be a power failure, the clock and RAM are protected with a battery-backup. Do the following to check and replace battery (removing the battery does not affect the LCD's configuration):

1. Turn OFF power.
2. Remove cover.
3. Remove battery.
4. Check battery.
5. If battery is faulty, replace battery with same type and rating. (TAC part number E17-129, 3.6V AA Non-rechargeable Lithium)
6. Re-install cover.
7. Turn ON power to LCD.
8. Dispose of battery properly.

BATTERY LOCATION

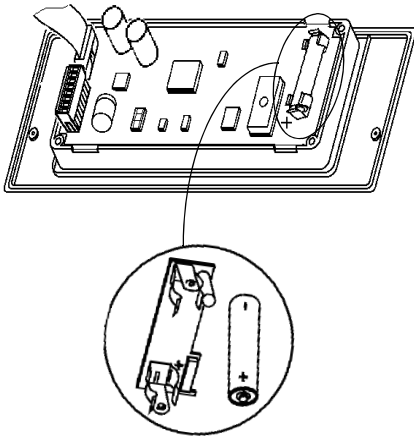

DIMENSION DRAWING

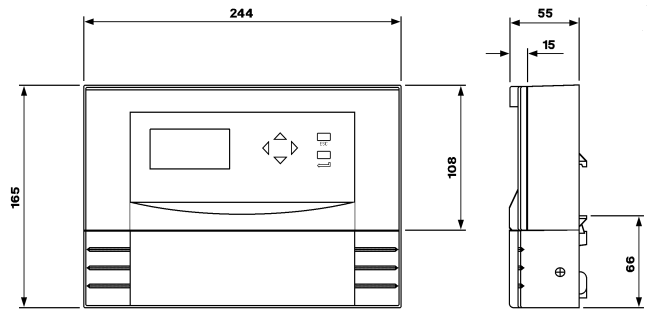

Dimensions in mm

Weights:

MN50-LCD 443g

Ribbon Cable 10g

WARNING -

THE LCD CONTAINS A LITHIUM CHLORIDE BATTERY WHICH IS COMPLETELY SAFE WHILST IN NORMAL USE. THE BATTERY MUST BE DISPOSED OF IN ACCORDANCE WITH LOCAL WASTE REGULATIONS.

Cautions

- Do not apply any voltages until a qualified technician has checked the system and the commissioning procedures have been completed.
- This is a 24Vac device. Do not exceed rated voltage. Local wiring regulations and usual safety precautions apply.
- 24Vac must be supplied by a transformer conforming to EN 61558.
- If any equipment covers have to be removed during the installation of this equipment, ensure that they are refitted after installation to comply with UL and CE safety requirements.
- Do not exceed the maximum ambient temperature.
- Interference with parts under sealed covers invalidates guarantee.
- The design and performance of TAC Satchwell equipment is subject to improvement and therefore liable to alteration without notice.
- Information is given for guidance only and TAC Satchwell does not accept responsibility for the selection or installation of its products unless information is given by the Company in writing relating to a specific application.
- A periodic system and tuning check of the control system is recommended.

Copyright © 2006 TAC AB

All brand names, trademarks and registered trademarks are the property of their respective owners. Information contained within this document is subject to change without notice. All rights reserved.

DS 10.060A 12/06

a company of
Schneider
Electric

TAC Headquarters
Malmö, Sweden
+46 40 38 68 50

Satchwell Helpline
+44 (0) 1753 611000
satchwell.info@uk.tac.com

www.tac.com

t.a.c.®
Satchwell