



MN550 Programmable Controllers

The Satchwell MicroNet MN550 Controllers are fully programmable controllers designed for district heating, boiler plant, air handling unit (AHU) and zone heating and cooling applications. These controllers feature plug-in field wiring terminal blocks, universal inputs, built-in line voltage relays, analogue outputs, pulse counting inputs and support for one MicroNet MN-Sx sensor.

MN550 controllers use fully-programmable control sequences based on a set of control objects residing in controller memory. The controllers can function in stand-alone mode (after programming with the VisiSat Configuration Tool) or as part of a LONWORKS® FTT-10 topology, a Native Communications Protocol (NCP) or an ARCNET® communications network.

An optional Real Time Clock Card (RTC) can be fitted to all variants of the MN550 to maintain the controller’s time during a power failure.

A Touch Screen Display option allows the user to view, query and edit controller properties. In addition, an LCD display can be connected (or fitted) to the controller to enable overrides and reviewing of the controller’s parameters.

FEATURES

- ARCNET and NCP (optically isolated) and LONWORKS FTT-10 communications options
- Fully programmable using graphical objects
- 24Vac or 24Vdc input power supply
- Time schedules for plant and controller switching
- 15Vdc supply output for humidity, pressure sensors, etc.
- S-Link sensor connectivity
- Ten fully configurable inputs - digital, analogue 0-10Vdc, resistive 0-10kΩ
- Optional battery-backed Real Time Clock (RTC) available for use on both networks or for stand-alone operation
- Capacitor-backed RAM (up to 1 week)
- LED diagnostics
- Proportional, integral and derivative control actions can be individually set in controller applications
- Optimisation module
- Optional LCD Display for interrogation of local parameters
- Intelligent multi-loop controller - up to 12 PID control loops
- Four analogue (0-10Vdc) outputs
- Six built-in line voltage relays, 230Vac 5A resistive
- Two inputs specially designed for pulse counting
- Suitable for applications such as district heating, boiler and air handling units
- Plug-in field wiring terminal blocks
- Wall or DIN rail mounting
- Connection to MicroNet View, TAC Xenta 555 web server and optionally, TAC Vista.

APPLICATIONS

Suitable for new or existing system installations, the MicroNet MN550 Controllers provide control for the following types of applications:

- Boiler Compensation and separate Hot Water Supply (HWS) system
- District Heating Sub-Station Control
- Boiler Sequence Control with a separate HWS system
- Full air conditioning including fan sequence control
- Zone heating and cooling systems

CONNECTIVITY

The MN550 Controllers can be attached directly to an MN-Sx Sensor allowing a user to monitor controller performance and edit operational values.

When used on an NCP or ARCNET communications network, MN550 controllers connect to a PC running VisiSat Configuration Tool and MicroNet View software, either directly using an ARCNET PC card or via the appropriate MicroNet Manager Interface (MN50-MI-NCP or MN50-MI-ARC). For a LONWORKS network, PC connection is direct (via LON® PC card) only.

In an SNP or NCP network, MN550 controllers can connect to a Xenta 555 web server via RS485, and in an ARCNET network, via an MN50-MI-ARC. MN550 LON controllers connect to the Xenta 555 at the LonWorks TP/FT-10 connection.

PART NUMBERS

MicroNet 550 ARCNET Controller	MN550-ARC
MicroNet 550 NCP Controller	MN550-NCP
MicroNet 550 Dual NCP Controller	MN550-XCOM
MicroNet 550 LON Controller	MN550-LON



TECHNICAL DATA

Supply voltage. 24Vac, 50/60Hz (supplied from a transformer conforming to EN 61558), or 24Vdc.
 Max. power consumption 12VA @ 24Vac, 6.5W @ 24Vdc
 Fuse. 1A anti-surge

Ambient Temperature

Shipping and Storage. -20°C to +70°C
 Operating 0°C to +50°C (when fitted with a plug-in Touch Screen Display, operating temperature is 0°C to 40°C).

Humidity

Operating and Storage 0 to 95% RH, non-condensing

Mechanical

Enclosure. Moulded ABS plastic case
 Flammability class UL 94 V-0
 Protection class IP 20
 Dimensions & Weight see Fig. 3
 Mounting Wall or 35mm DIN rail. On or in a control appliance
 Wiring Terminals: Pluggable screw terminal blocks (low voltage only). Max. conductor size 1.5mm².

Real Time Clock Module (optional)

Accuracy at +25 °C ±10 minutes per year
 Battery. Lithium, 3V, 125mAh. Battery life 5 years minimum

Communications

NCP. 9.6k baud, RS 485
 ARCNET 156k baud, RS 485
 LONWORKS FTT-10 Free Topology up to 78k baud

Agency Compliances

CE. CE Compliant
 EMC EN 61326 (Emissions) Class A (FCC Class A)
 EN 61326 (Immunity)
 LVD. EN 60950 2001 (Safety IT)
 EN 60730-1 2001 (Safety) (pollution degree 2, impulse voltage 2.5kV)

Power Failure Reserve

Controller EEPROM preserves memory for 10 years under normal conditions of use. RAM contents will be preserved for up to one week in the event of a mains power failure, by a back-up capacitor. The software clock will stop during a power failure. If the controller has an RTC card, then the time will be maintained.

INPUTS AND OUTPUTS

I/O Point Type	Description	Quantity
Universal Input (UI)	Each separately jumper configurable for either resistive (0-10KΩ, 0 - 10Vdc or digital use).	10
Pulse Counting Input	Dry contact, each capable of counting up to 10 pulses per second. Note: the actual speed depends on the application time cycle time, i.e. how often the pulse input signal is passed to a counter module. Typically this is 2Hz or less.	2
Analogue Output (AO)	0 - 10Vdc (at 1mA) for analogue actuator or transducer control (10KΩ minimum input load).	4
Relay output	Line Relay Outputs, 5A resistive, Type 1B. Current Rating: 5A at 230Vac. See cautions on page 4.	6
Sensor Link	Sensor Link for MicroNet S-Link sensor. Input comprises: Space Temperature (0°C to 50°C); Adjustable Setpoints (4.4°C to 35°C); Operational Mode (Heat/Cool/Auto/Off); Fan (On/Speed (Low/Medium/High)/Auto); Override Pushbutton (standalone occupancy control or remote status monitoring of local status condition). These features are programmable in VisiSat.	1
15Vdc Output	15Vdc (25mA) supply output for humidity and pressure sensors etc.	1

ACCESSORIES

LIB-4-485 RS 232/RS 485 Converter to connect PC to NCP network
 PCI20-485 or PCI20U-485 PCI card* to connect PC to ARCNET network. Type depends on PC's motherboard.
 PCM20H-485 PCMCIA card* to connect Laptop to ARCNET network.
 *PCI and PCMCIA cards available from Contemporary Controls (www.ccontrols.com).
 Echelon® ECH 74501 PCLTA21/FT-10 PCI card to connect Desktop PC to LONWORKS FTT-10 network
 Echelon® ECH 73200 PCC-10 TP/FT-10 card to connect Laptop PC to LONWORKS FTT-10 network
 LON-TERM1 Single LON Terminator for Free Topologies
 LON-TERM2 Double LON Terminator for Bus Topologies (two required)
 MN-Sx. MicroNet Sensors
 MN50-LCD/MN50-LCDP MicroNet LCD Displays (wall/panel mounting)
 MN50-TS-100/MN50-TSP-100. MicroNet Touch NCP Screen Displays (wall/panel mounting)
 MN-DK Display Wall Mounting Kit for LCD/Touch Screen
 MN50-MI-ARC/NCP. MicroNet Manager Interface for ARCNET/NCP networks
 MN50-MI-RTR ARCNET Router
 MN50-RTC Real Time Clock Card for MN Series Controllers (not supported for LON variants)
 MN-TK Trunking Mounting Kit
 MN-VSCORE. VisiSat Configuration Tool (requires Visio 2003 software), core software (NCP & ARCNET).
 MN-VSLON. VisiSat LON plug-in (requires MN-VSCORE), required for MN550-LON
 0-073-0825. TAC Xenta 555 Web Server
 0-073-0902. TAC Xenta 400 (Terminal Part)

TYPICAL SYSTEM DIAGRAM

MICRONET MN550 CONTROLLER

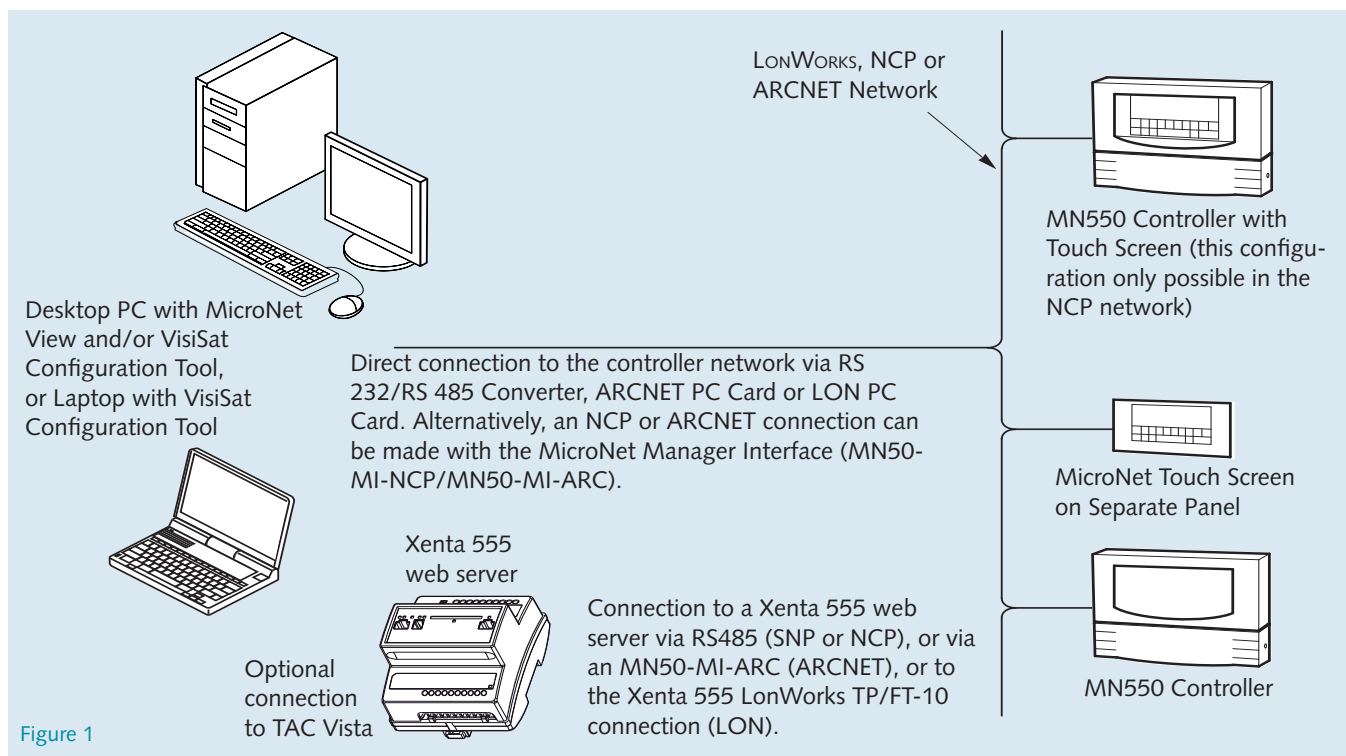

COMMUNICATIONS

ARCNET

If an open communications standard is not necessary, but peer-to-peer communications is required, the high-performance ARCNET network option may be implemented. This network is created by using ARCNET controllers (e.g. MN550-ARC) and a MicroNet Manager Interface (MN50-MI-ARC).

An ARCNET communications network has a communications speed of 156k baud and can host up to 95 devices per sub-LAN (and up to 31 sub-LANs using ARCNET Routers).

ARCNET controllers communicate with each other in a peer-to-peer mode and connect to the MicroNet View software via an MN50-MI-ARC only and with the VisiSat Configuration Tool software via an MN50-MI-ARC or an ARCNET PC card.

An optional MicroNet Touch Screen Display can be mounted on a self-contained panel and connected to the MN550-ARC variant.

An optional LCD Display, when mounted remotely, can be connected to an MN550-ARC controller operating in stand-alone mode. In addition, the LCD can be connected to an MN550-ARC variant in an ARCNET network.

The LCD can be also be mounted directly on an MN550-ARC controller in stand-alone mode (using a ribbon cable).

NCP (Native Communications Protocol)

In cases where an open communications standard is not required, an NCP network can be used.

An NCP network has a communications speed of 9.6k baud and can host up to 20 sub-networks with 63 devices each communicating in a polled-response mode.

Controllers on an NCP network (e.g. MN550-NCP) connect to MicroNet View and the VisiSat Configuration Tool via a direct connection to the PC using an RS 232/RS 485 Converter. Alternatively, connection can be via a MicroNet Manager Interface (MN50-MI-NCP).

An optional MicroNet Touch Screen Display can be mounted directly on the controller or on a self-contained panel.

An optional LCD Display, when mounted remotely, can be connected to an MN550-NCP controller operating in stand-alone mode. In addition, the LCD can be connected to an MN550-XCOM variant in an NCP network.

The LCD can be also be mounted directly on any MN550-NCP controller in stand-alone mode (using a ribbon cable).

LONWORKS

A LONWORKS FTT-10 Free Topology communications network has a communications speed of up to 78k baud and can host up to 63 devices per segment (this can be increased to 128 using a repeater). See www.echelon.com/support for network design and wiring requirements.

LONWORKS network controllers (e.g. MN550-LON) communicate with each other in a peer-to-peer fashion and connect to MicroNet View and

the VisiSat Configuration Tool via the standard LON FTT-10 cards.

MicroNet View provides alarm management and dynamic trend logging. Applications can be prepared and downloaded to MicroNet controllers from the VisiSat Configuration Tool.

S-Link Sensor

A Sensor Link (S-Link) (two-wire, unshielded, communications wiring) provides a power and communication interface to an MicroNet (MN-Sx) series sensor. From some MN-Sx models, the user can view and adjust application parameters. A maximum of 61m is allowed between the MN550 controller and the MicroNet Sensor.

DOCUMENTATION

- MN550 Wiring & Commissioning - DS 10.153A
- MN550 Installation Instructions - MLI 10.153
- MicroNet Manager Interface - DS 10.217
- MicroNet MN-Sx Sensors - DS 10.000
- MicroNet Touch Screen - DS 10.050
- MicroNet LCD Display - DS 10.060
- MicroNet View - DS 10.201
- VisiSat Configuration Tool - DS 10.202
- VisiSat Engineering Guide
- MicroNet System Overview
- MicroNet System Engineering Guide
- TAC Xenta 555 - 03-00044-01-en.

DIMENSIONS

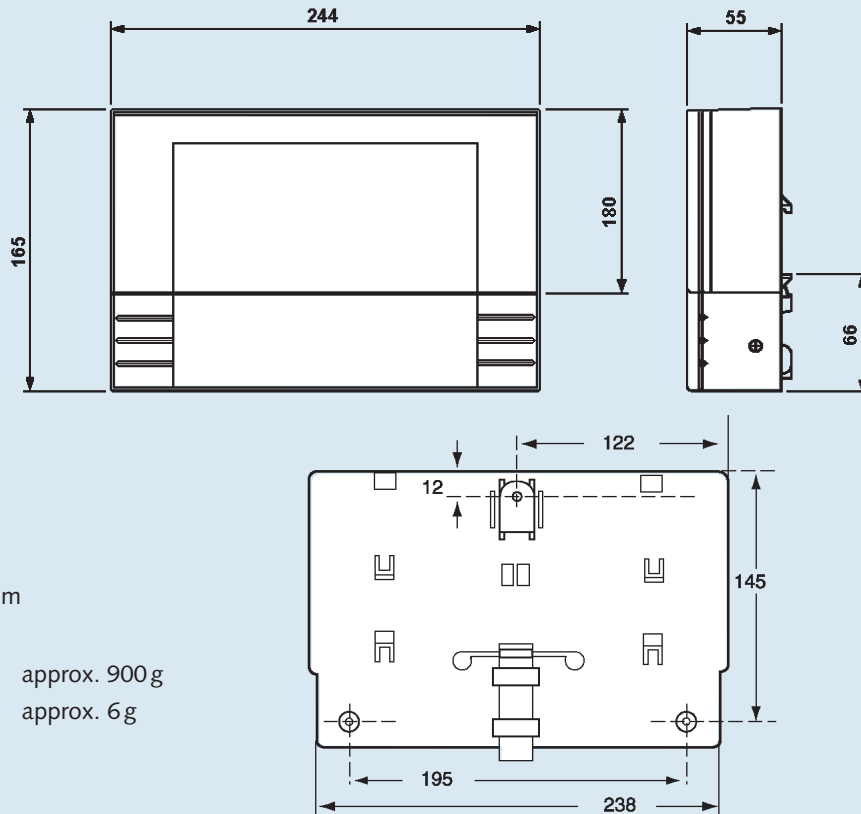

Figure 2

WARNINGS

1. THIS DEVICE OPERATES FROM 24Vac or 24Vdc. DO NOT EXCEED RATED VOLTAGE. LOCAL WIRING REGULATIONS AND USUAL SAFETY PRECAUTIONS APPLY.
2. ELECTRICAL SHOCK HAZARD. REMOVE ALL POWER FROM BOTH THE CONTROLLER AND RELAY OUTPUTS BEFORE MAKING TERMINATIONS OR CHANGING CONFIGURATION INPUT JUMPERS.
3. RELAY OUTPUTS COULD BE AT MAINS POTENTIAL.

Cautions

- Do not apply any voltages until a qualified technician has checked the system and the commissioning procedures have been completed.
- If any equipment covers have to be removed during the installation of this equipment, ensure that they are refitted after installation to comply with UL and CE safety requirements.
- 24Vac must be supplied by a transformer conforming to EN 61558.
- Do not exceed the maximum ambient temperature.
- Interference with parts under sealed covers invalidates guarantee.
- Do not charge, short-circuit or solder the MN50-RTC battery. Do not allow contact with water, nor heat, disassemble or dispose of in fire. Do not reverse polarity in application.
- Do not route relay output wiring with any other controller wiring.
- Do not route power and output wiring with signal wiring.
- Do not run Extra Low Voltage (24Vac or less) wiring in the same harness as mains wiring.
- The design and performance of TAC Satchwell equipment is subject to improvement and therefore liable to alteration without notice.
- Information is given for guidance only and TAC Satchwell does not accept responsibility for the selection or installation of its products unless information is given by the company in writing relating to a specific application.
- A periodic check of the Building Management System is recommended. Please contact your local sales office for details.
- All installation wiring must conform to BS 6701:2004 & EN 50174.

Copyright © 2006, TAC
All brand names, trademarks and registered trademarks are the property of their respective owners. Information contained within this document is subject to change without notice. All rights reserved.

TAC Headquarters
Malmö, Sweden
+46 40 38 68 50

Satchwell Helpline
+44 (0) 1753 611000
satchwell.info@uk.tac.com

DS 10.153 12/06



CE www.tac.com

t.a.c. 
Satchwell