

### WIRING AND COMMISSIONING INFORMATION FOR MICRONET MANAGER INTERFACE/ARCNET® ROUTER

#### APPLICATION

Order Type:

MN50-MI-ARC- MicroNet ARCNET Interface  
 MN50-MI-NCP MicroNet NCP Interface  
 MN50-MI-RTR ARCNET Router

#### MicroNet Manager Interface (MN50-MI-ARC and MN50-MI-NCP)

The MicroNet Manager Interface (also referred to generally as the MN MI) provides the network-level management functions for a network of ARCNET® or NCP MicroNet controllers and Touch Screens. Two variants are available, one for ARCNET networks and another for NCP networks.

On an ARCNET network, the MN50-MI-ARC can supervise a flat LAN of up to 95 controllers and Touch Screens. Alternatively, up to 31 sub-LANs can be created using ARCNET routers, with each sub-LAN allowing up to 95 controllers, Touch Screens and further routers to be connected. If sub-LANs are used, the main LAN must connect only to routers; controllers and Touch Screens are not permitted on the main LAN if routers are also used.

On an NCP network, the MN50-MI-NCP can supervise up to 63 devices on the main LAN, plus 63 devices on each of the possible 20 sub-LANs. In NCP networks, sub-LANS are created using Touch Screens.

An RS 232 port on the MN MI provides a connection to a PC running the VisiSat™ Configuration Tool or MicroNet View software, or to a modem for remote access. A second RS 232 port can be used for an additional connection to the VisiSat Configuration Tool when the primary port is occupied by the modem.

The MN MI is also capable of programmable alarm polling and data logging via the MicroNet View software. MN MI polling is able to track up to 512 'points' among controllers on the network, both for local log storage and alarm detection (refer to the *MicroNet View Engineering Guide* for further information.)

The MN MI features password protection to stop unauthorised computers from interrogating remote sites.

#### ARCNET Router (MN50-MI-RTR)

The MicroNet ARCNET router is used to increase both the wiring length of an ARCNET network and the number of controllers that can be used.

Connecting an ARCNET router creates a new branch of the LAN, known as a sub-LAN, to which other ARCNET controllers, Touch Screens and ARCNET routers can be connected. An ARCNET network can contain up to 31 sub-LANs, each allowing a further 95 devices to be connected.

For performance reasons, when transferring network variables between controllers and Touch Screens, the main LAN should have only ARCNET routers connected to it, unless there are no sub-LANs.

The maximum wiring path between the two most distant devices on the main LAN must not exceed 800m. However, a maximum of five routers can be cascaded to increase the maximum routing length to 4.8km.

Note: To maintain network performance, the network must be organised to ensure that data (network variables) transferred between controllers does not have to pass through a router.

#### Real Time Clock

All devices contain a built-in RTC that can be used for network time synchronisation. For the ARCNET Router, this feature can be used if an MN MI is not used at the head of the network. A Lithium battery provides backup power for the RTC for up to 350 days if external power is lost. Refer to the *VisiSat Engineering Guide* for details of time synchronisation.

#### SPECIFICATIONS

Order Type	Description	Communications
MN50-MI-ARC	MicroNet Interface	ARCNET
MN50-MI-NCP	MicroNet Interface	NCP
MN50-MI-RTR	ARCNET Router	ARCNET



#### Data Sheets

DS 10.217 - MicroNet Manager Interface/ARCNET Router  
 DS 10.201 - MicroNet View Software  
 DS 10.202 - VisiSat Configuration Tool

#### Multi-Lingual Instructions

MLI 10.217 - Installation Instructions  
 MLI 10.300 - MNA-C Installation



## INSTALLATION

### Inspection

Inspect carton for damage. If damaged, notify carrier immediately. Inspect the device for damage. Return damaged products.

### Requirements

(These items are not provided)

- Installer must be an experienced technician
- Job wiring diagrams
- Tools:
  - Drill and bits
  - Digital Volt- $\Omega$  meter (DVM)
  - Static protection wrist strap
- An EN 61558 power transformer as described opposite.
- Three No. 10 self-starting screws for wall mounting or 35mm DIN rail for mounting.

For the MN MIs only:

- Null modem cable for RS 232 connection to PC, TAC Satchwell part number CBL-002.
- Cable for RS 232 connection to modem, TAC Satchwell part number CBL-003.

### Modem (MN MIs Only)

When an MN MI communicates via modem, US Robotics brand automatic-switching modems (such as the 56K Fax Modem Model #5630) are recommended. This brand of modem has been tested and found to work satisfactorily with the MicroNet system. Other modem brands that are capable of transferring data at 9600 baud and higher may also function properly. If you wish to use another brand of modem, please contact your local sales office for the latest information on approved models.

### Precautions

#### General

- Follow Static precautions when installing this equipment.
- Use copper conductors that are suitable for 75°C.
- Make all connections according to electrical wiring diagram, national and local electrical codes.

#### Static Precautions

Static charges damage electronic components. The microprocessor and associated circuitry are extremely sensitive to static discharge. Use the following precautions when installing, servicing, or operating the system:

- Work in a static-free area.
- Discharge static electricity by touching a known, securely grounded object.
- Use a wrist strap connected to earth ground when handling the device's printed circuit board.

#### European Community Directives

This equipment meets all requirements of European Community Directives for Low Voltage (72/23/EEC), General Safety (92/59/EEC), and Electromagnetic Compatibility (89/336/EEC).

#### Federal Communications Commission (FCC)

This equipment has been tested and found to comply with the limits for a Class A digital device, pursuant to Part 15 of the FCC Rules. These limits are designed to provide reasonable protection against harmful interference when the equipment is operated in a commercial environment. This equipment generates, uses, and can radiate radio frequency energy and, if not installed and used in accordance with the instruction manual, may cause harmful interference to radio communications. Operation of this equipment in a residential area is likely to cause harmful interference in which case the user will be required to correct the interference at his own expense.

#### Canadian Department of Communications (DOC)

This digital apparatus does not exceed the Class A limits for radio noise emissions from digital apparatus set out in the radio interference regulations of the Canadian Department of Communications.

### Power Supply Wiring Precautions

- This product contains a non-isolated half-wave rectifier power supply and must not be powered by transformers used to power other devices containing non-isolated full-wave rectifier power supplies. Refer to DS 10.250, *EN-206, Guidelines for Powering Multiple Full-Wave and Half-Wave Rectifier Devices from a Common Transformer* for detailed information.
- The 24Vac 50/60Hz supply must comply with EN 61558 and be capable of supplying at least 5VA. Class 2 circuits must not intermix with Class 1 circuits. The supply to the transformer must have a breaker or disconnect.
- The transformer frame and the device's GND terminal must be connected to earth; see page 6.

# Mounting

## Panel or DIN Rail Mounting

1. Select mounting location. Allow minimum 150mm clearance around the device.
2. Do the following to mount the device on a panel:
  - a. Loosen two screws securing terminal cover and remove cover.
  - b. If not already fitted, press the wall mounting clip into the back of the device.
  - c. Lift wall mounting bracket clip. (Located on top back of the device.)
  - d. Using a No. 10 self-starting screw, install top screw.
  - e. Lift and level the device.
  - f. Using two No. 10 self-starting screws, install bottom screws.
  - g. Re-install terminal cover. (May be left off until wiring is completed.)
3. Do the following to mount the device on a DIN rail:
  - a. While pulling down on DIN rail locking bracket, snap the device base on a 35mm DIN mounting rail.
  - b. Release DIN rail locking bracket.
  - c. Press bottom of the device on 35mm DIN mounting rail.

### MOUNTING METHODS

# Location

These devices are suitable for indoor use only. When selecting a mounting location, make certain the following conditions are met:

- Do not install where excessive moisture, corrosive fumes, vibration, or explosive vapours are present.
- Do not install near large contactors, electrical machinery, or welding equipment.
- Allow 150mm clearance from contactors, switches, and associated cabling.

Locate where ambient temperatures do not exceed 50°C or fall below 0°C and relative humidity does not exceed 95% or fall below 5%, non-condensing.

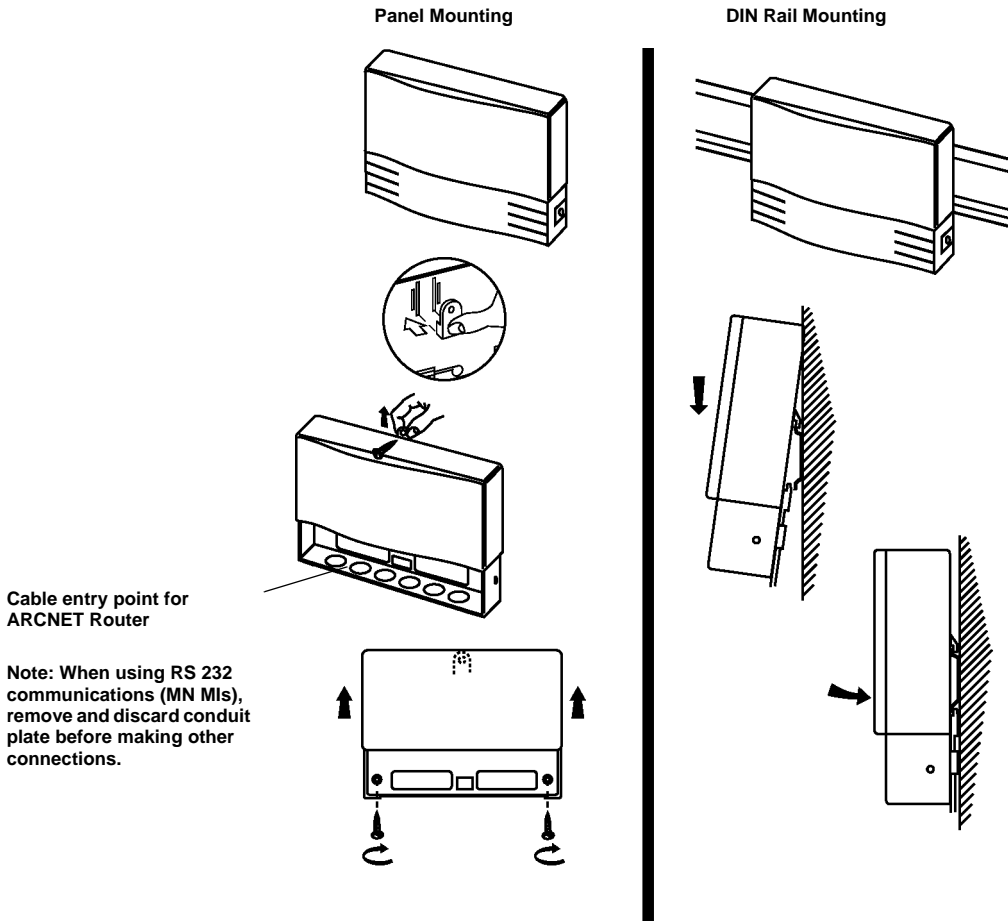

## Terminal Connections

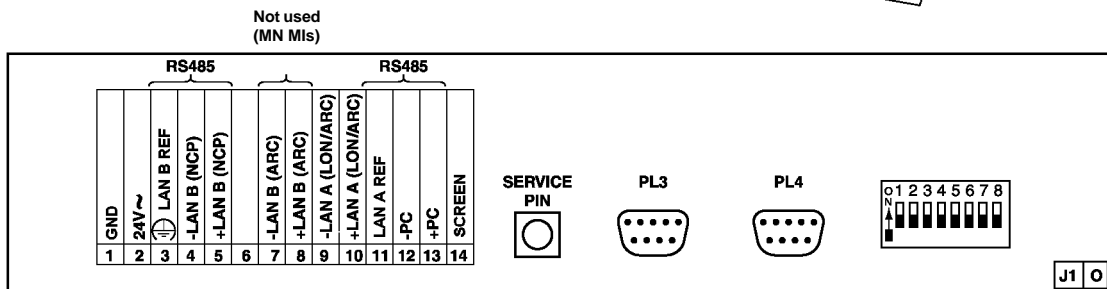
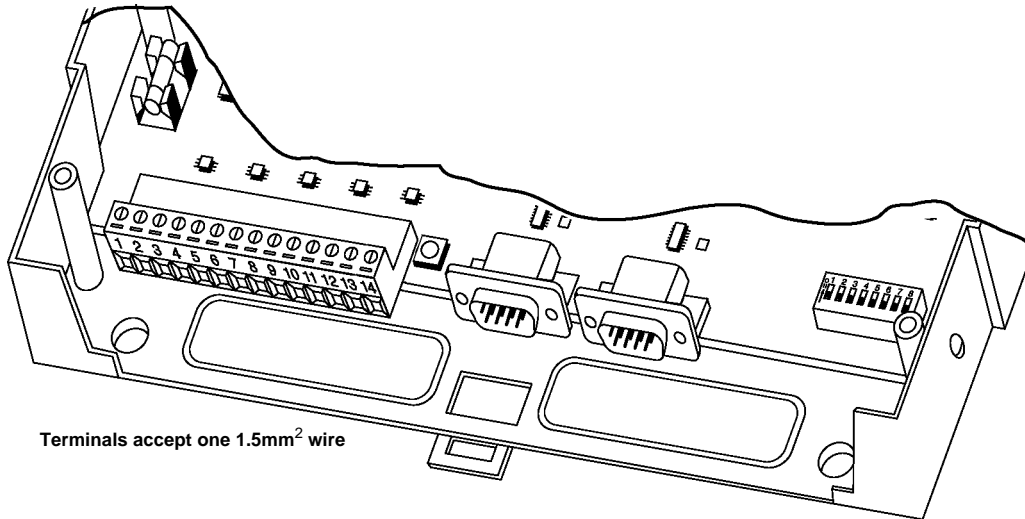

## Network Wiring



**WARNING - ELECTRICAL SHOCK HAZARD.**  
**THE MN350 AND MN550 CAN CONTAIN MAINS VOLTAGES. REMOVE ALL POWER FROM BOTH THE CONTROLLER AND DIGITAL OUTPUTS BEFORE MAKING CONNECTIONS OR CHANGING JUMPERS.**

### Introduction

Network wiring includes a connection between an MN MI and a MicroNet controller network. Depending on the specific controller model, one of two network types can be used:

- ARCNET networks
- NCP networks.

### Cautions

**Note that termination of cable screens can be critical to performance, particularly in an ARCNET network.**

**Network wire pairs must be dedicated to MicroNet network communications. They cannot be part of an active, bundled telephone trunk.**

**If network cable is installed in areas of high RFI/EMI, the cable must be in conduit.**

**Do not route network wiring with power wiring.**

**Refer to the *MicroNet System Engineering Guide* for further guidance, including network topologies, wiring, network lengths, termination and cable types.**

### Network Screens

Earth each screen, but at only one end of the cable. If earthing a screen at a MN MI/Router, connect to terminal 14. Terminal 3 also needs to be connected to earth to improve noise performance. Keep wires emerging from screened cable as short as possible.

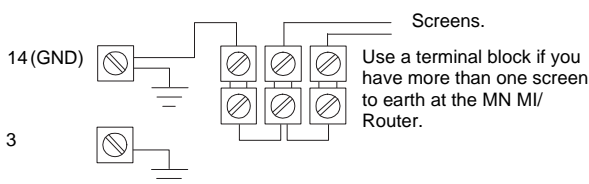

Note: Satisfactory NCP or ARCNET communications relies on the LAN REF potential varying no more than 7V between any two devices in the network (e.g. between an MN MI and any controller, or between any two controllers). If this is not the case, you need to introduce NCP repeaters or ARCNET routers and connect the network screens and terminal 3 as detailed in the *MicroNet System Engineering Guide*.

## NCP Network Wiring (MN50-MI-NCP Only)

Recommended cable for NCP networks is Belden 9502 dual twisted-pair screened cable.

1. Review Precautions section.
2. Connect the network to the MN50-MI-NCP, as shown in the following diagram. **Observe correct polarity.**

Note: Connect the MN MI with other NCP devices in a device-to-device fashion. Do not use wiring trees or stubs.

Note: Ground the wiring screen **at one end of the cable only.**

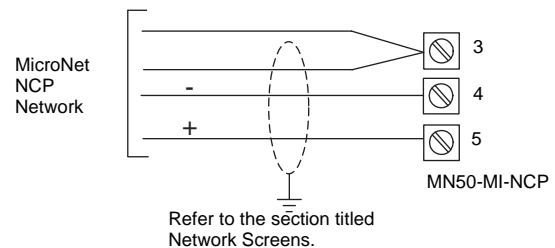

## ARCNET Network Wiring

Recommended cable for ARCNET networks is Belden 9502 dual twisted-pair screened cable.

1. Review Precautions section.
2. If wiring an MN-MI, connect the network to the MN50-MI-ARC as shown in the following diagram. **Observe correct polarity.**

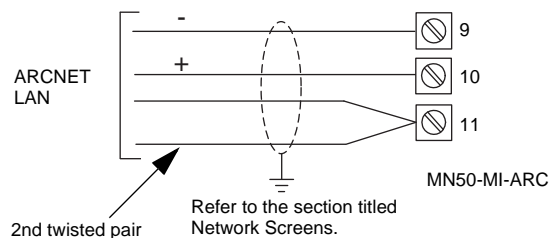

Connect the MN50-MI-ARC with other ARCNET devices in a device-to-device fashion. Do not use wiring trees or stubs. Also, ground the wiring screen **at one end of the cable only.**

3. If wiring an ARCNET Router, connect terminals 9 and 10 to the network from which the router hangs (e.g. the network from the MN50-MI-ARC). **Observe correct polarity.**

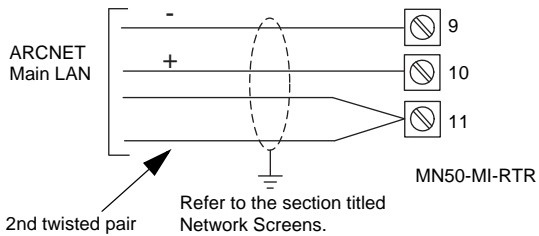

Connect the MN50-MI-ARC with other ARCNET devices in a device-to-device fashion. Do not use wiring trees or stubs. Also, ground the wiring screen **at one end of the cable only**.

- If creating a router sub-LAN, connect the sub-LAN to terminals 7 and 8 of the router. **Observe correct polarity.**

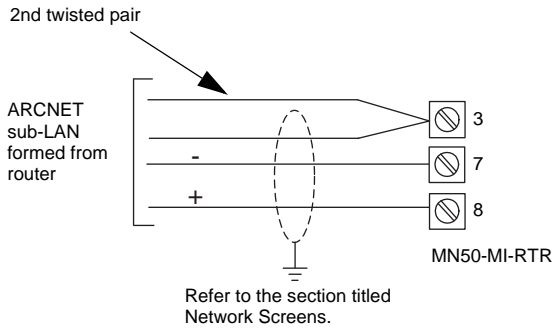

- The devices *at each end* of the network connected to terminals 9 and 10 of the MN MI must be biased and terminated by fitting jumpers to links LK1, LK2 and LK11 on the MN MI's ARCNET card, as shown in the following diagram. If the MN MI is not at one end, leave the links unset.

ARCNET termination and biasing links (in MN50-MI-ARC)

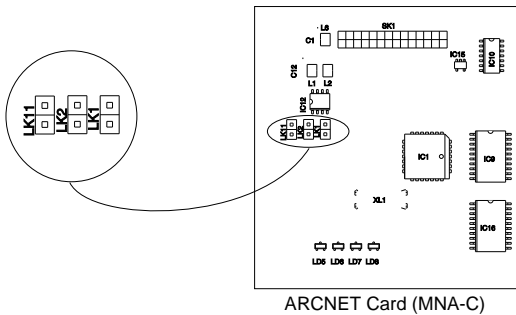

- The devices *at each end* of the network connected to terminals 7 and 8 of the router (the sub-LAN) must be biased and terminated by fitting jumpers to links LK8, LK9 and LK10 on the router's ARCNET card (MNR-C). The router is normally at one end, and therefore these links should normally be set. If the router is not at one end, leave the links unset.

ARCNET termination and biasing links (in ARCNET Router)

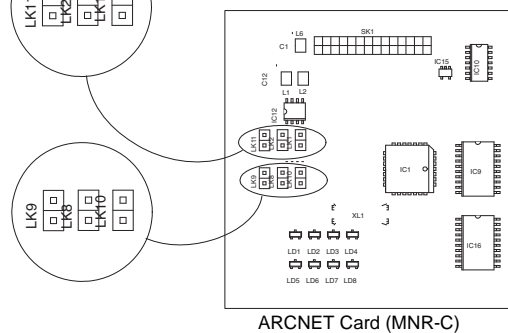

### RS 232 Communication Wiring to a PC or Modem (MN\_MIs Only)

Either RS 232 port on the MN MI (PL3 or PL4) can be connected to a PC for communication to VisiSat or MicroNet View.

If you want to connect a modem to the MN MI for remote access to controllers, you must connect it to PL4, since the MN MI can dial out only from PL4 to report alarms. A modem can be connected to PL3 for communication with VisiSat or MicroNet View, but the MN MI will not dial out from this port to report alarms.

- Review Precautions section.
- Remove and discard conduit plate.
- Connect 9-pin female RS 232 connector to PL3 or PL4 on MN MI.
- Connect other end of cable to computer or modem. (Do not exceed 15m in length.)

Cable CBL-002  
For 9-Pin PC COM Port

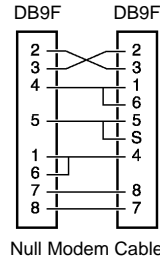

Null Modem Cable

Cable CBL-003  
For 25-Pin Modem

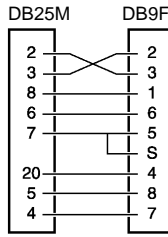

Refer to page 2 for recommended modems

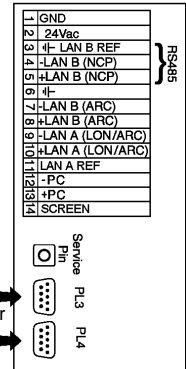

### TAC Xenta 555 Web Server Interface

The MN MI can interface with a TAC Xenta 555 controller and ultimately, to TAC Vista. For Xenta 555 connection details, refer to the *TAC Xenta 511/527/555/911/913 Product Manual*.

### BATTERY SETUP

The unit is shipped with the battery disabled to preserve battery life. To enable the battery, do the following:

- Remove battery.
- Remove protective strip from battery.

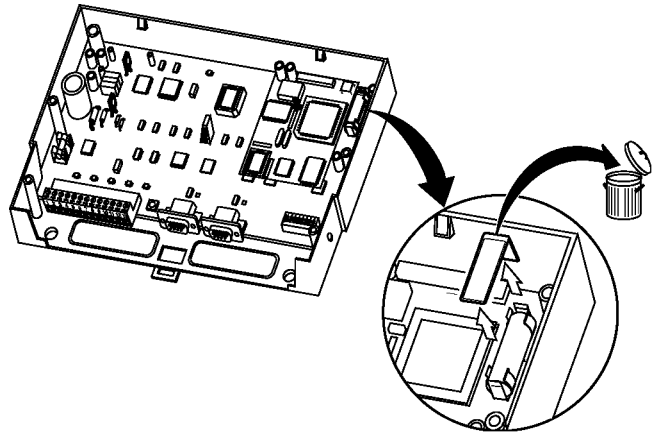

- Re-install battery. (Make certain polarity is correct.)
- Make certain battery is fully seated in battery holder.

## Power Supply Wiring

### Notes:

1. This product contains a non-isolated half-wave rectifier power supply and must not be powered by transformers used to power other devices containing non-isolated full-wave rectifier power supplies. If multiple devices are powered from the same transformer, verify that the transformer is properly sized to power all equipment simultaneously and all devices contain the same type of rectifier power supplies or internal isolation. Also verify that correct polarity has been maintained between all connected devices. Refer to DS 10.250, *EN-206, Guidelines for Powering Multiple Full-Wave and Half-Wave Rectifier Devices from a Common Transformer* for detailed information.
2. Install wiring according to job wiring diagrams and local electrical codes.
3. The wire gauge used must be consistent with load current rating.

### 24Vac Power Wiring

1. Review Precautions section.
2. Ensure that the device's GND terminal is connected to Earth **before** connecting the power wiring to the device.
3. Connect power ground wiring to terminal 1.
4. Connect power 24Vac wiring to terminal 2.

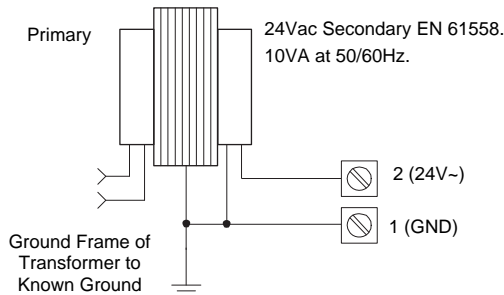

## CHECKOUT

### Electrical Checkout

1. Verify network wiring between the MN MI/Router and other devices is installed according to job wiring diagram and national and local electrical codes.
2. Verify 24Vac power is provided from a power transformer conforming to EN 61558 and wiring is installed according to job wiring diagrams and with national and local electrical codes.
3. For an MN MI, verify RS 232 communication is wired according to job wiring diagram and with national and local electrical codes.

### Cold and Warm Starting the Device

#### Cold Start

Caution: The cold start procedure clears *all* configuration data from the non-volatile EEPROM of the device and reloads default settings.

A cold start is normally performed only once when the device is first installed. The cold start is performed using bit switch S1, as shown in the following diagram. Perform a cold start before setting up MN MI/Router addressing.

To perform a cold start:

1. Energise the device and verify that the RUN LED flashes at about once per second.
2. Place only switch 1 in the ON position. **The remaining switches must be in the OFF position.**
3. Place bit switch 8 in ON position and then return to OFF position. You should see the RUN, WINK and MODEM LEDs remain lit for about 1.5 seconds, then the RUN LED should flash at about once per second.

Note: This is different from the cold-start procedure for a controller, which requires you simply to toggle switch 8.

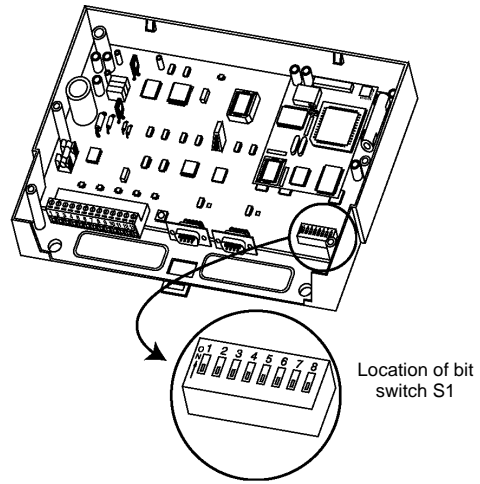

#### Warm Start

When the device is warm started, all EEPROM-resident values are retained. You may want to perform a warm start in the unlikely event that there is a concern that the device is not working correctly.

To perform a warm start, select **Reset** in the MN MI's/Router's properties in VisiSat. Alternatively, switch off power to the device, wait 15 seconds, then reapply power.

### Addressing

#### MN MI Addressing

It is essential for switches 1 to 4 in bit switch S1 to be set to the ON position to ensure addressing compatibility with VisiSat and MicroNet View.

To set up addressing:

1. After cold starting the MN MI, set switches 1 to 4 to ON. **The other switches must be OFF.**
2. Place bit switch 8 in ON position and then return to OFF position. This actions the address change. Addressing will not be set up correctly if you do not do this.

The address of the MN MI is fixed as subnet 0, node 0, which is a special point-to-point address.

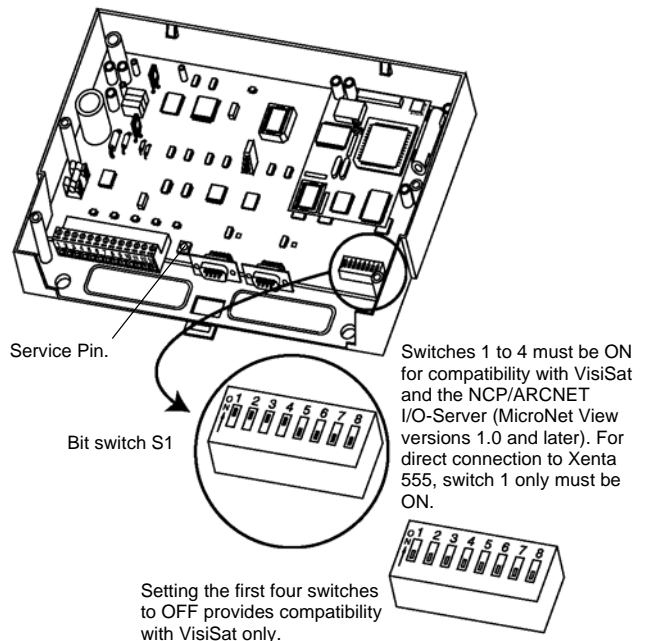

#### ARCNET Router Addressing

After cold starting the router, you need to set up its address.

Each router needs a unique node address. Although the node address of two controllers or Touch Screens can be the same if they are on different ARCNET sub-LANs (i.e. separated by a router), the node address of a router must not be the same as the node address of any other router anywhere on the entire network. The reason for this is that the router's node address is used as the subnet address of the sub-LAN it creates, and no two sub-LANs can have the same subnet address.

1. Set the node address using switches 1 to 6 in bit switch S1, as shown in the following table. **Do not use a node address of 1, as this will create a subnet address that clashes with the subnet address of the main LAN.**
2. Place bit switch 7 in ON position. This sets Router mode of operation.
3. Place bit switch 8 in ON position and then return to OFF position. This actions the address change. Addressing will not be set up correctly if you do not do this.

**ARCNET ROUTER ADDRESS**

Switch Number	OFF Position	ON Position
1	0	1
2	0	2
3	0	4
4	0	8
5	0	16
6	0	32

**Example:** Placing switches 1, 3 and 6 in the ON position and switches 2, 4 and 5 in the OFF position sets router address to 37:

Switch Number	OFF Position	ON Position
1	ON	1
2	OFF	0
3	ON	4
4	OFF	0
5	OFF	0
6	ON	32
TOTAL		Node Address = 37

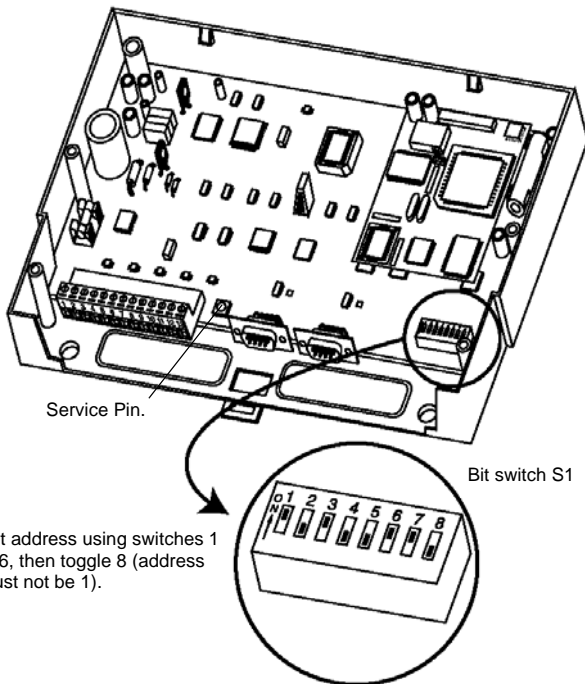

**Service Pin**

When a router is installed, the Service Pin is relevant only if there is no MN MI at the head of the ARCNET network.

The MN MI/Router sends a broadcast message to every device below it in the network when it is cold started and (for the router, if an MN MI is not detected) every five minutes thereafter. This message enables each device to obtain its subnet address. It is essential for each device on the network to obtain its subnet address before communications can take place between devices and between the device and VisiSat or MicroNet View.

After connecting a new device to an existing network that is already in operation, you may want to broadcast the subnet address immediately, so that the device can be addressed straight away. You can do this by pressing the Service Pin on the device's PCB or by selecting **Service Pin** in the device's properties in VisiSat. (A router object can be placed in VisiSat using the MN MI object and setting the address accordingly.)

**COMMUNICATIONS CHECKOUT**

**MN MI/Router LEDs**

The LEDs have the following meanings:

RUN (green)	Steady ON for about 1.5 seconds at power-up - the device is operating properly.
	Flashes at 50% on, 50% off rate "heartbeat" - Device is operating properly, and has good communication.
	Flashes at 25% on, 75% off rate - Indicates no or bad communications.
	RUN, MODEM and WINK LEDs flash rapidly - Unit has an internal software error (warm start the MN MI/Router).
MODEM (yellow))	OFF - No modem detected (normal condition for router).
	Steady ON - Modem is online (MN MIs).
	Blinks every 2 seconds - Modem detected and currently idle (MN MIs).
WINK (red)	Blinks rapidly - Indicates initialising or searching for modem.
	OFF - Normal.
MASTER RX (yellow)	Flashes rapidly when several times on cold start or when Service Pin is pressed - Normal.
	Flashes rapidly when receiving data through the serial PL4 port.
LAN RX (yellow)	Flashes rapidly when receiving data from device on and NCP network (not used for ARCNET networks).

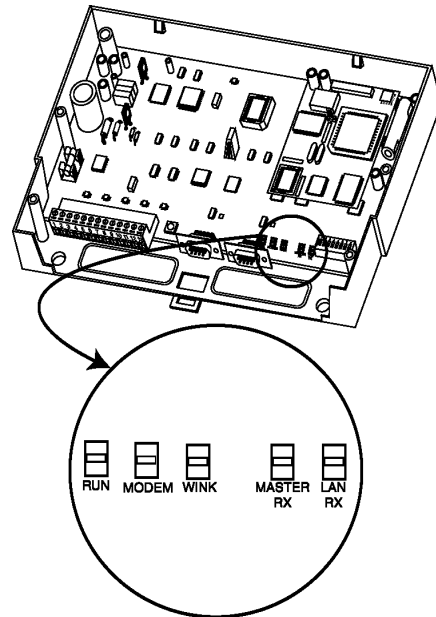

**ARCNET Card LEDs**

LEDs LD5 to LD8 show status information relating to the ARCNET network from which the ARCNET router hangs (e.g. the main LAN) and have the following meanings for all devices:

LD5 (Green, 'Online' LED)	ON when node is online (normal use). OFF when node is off line.
LD6 (Red, 'Error' LED)	OFF when no network errors. ON when duplicate node on network, or if network is reconfiguring. Flickering when bad data packet received.
LD7 (Yellow 'Rx' LED)	ON when data packet received.
LD8 (Yellow 'Tx' LED)	ON when data packets transmitted.

For the router, LEDs 1 to 4 are assigned to channel B (the sub-LAN formed from the router) and have the same meanings as LEDs 5 to 8. Refer to the *MicroNet System Engineering Guide* for further information about the ARCNET LEDs.

## SERVICING

Components within these devices cannot be field repaired. If there is a problem with any device, follow the steps below before contacting your local sales office:

1. Make sure the device is connected and communicating to desired devices.
2. Cold start the device and set up addressing again.
3. If the MN MI is operating, make sure the MN MI properties are correct using the VisiSat Configuration Tool. For more information, see *VisiSat Engineering Guide*.
4. Record precise hardware setup indicating the following:
  - Device firmware version number.
  - Information regarding the VisiSat Configuration Tool (Help About VisiSat).
  - A complete description of difficulties encountered.

## Fuse Replacement

A fuse (1A, anti-surge) provides overcurrent protection for the device. Do the following to check and replace fuse:

1. Turn OFF power to the device.
2. Remove cover.
3. Remove fuse.
4. Check continuity across fuse. If fuse is faulty, replace fuse with same type and rating.
5. Re-install cover and turn ON power to the device.

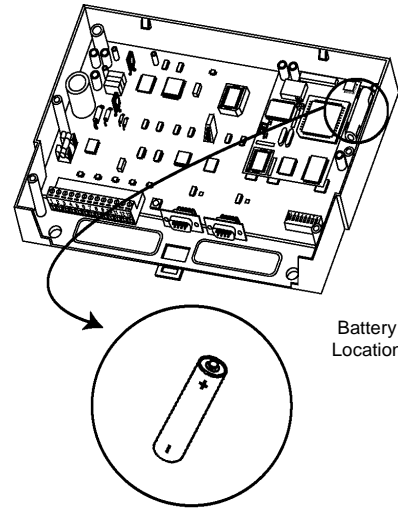
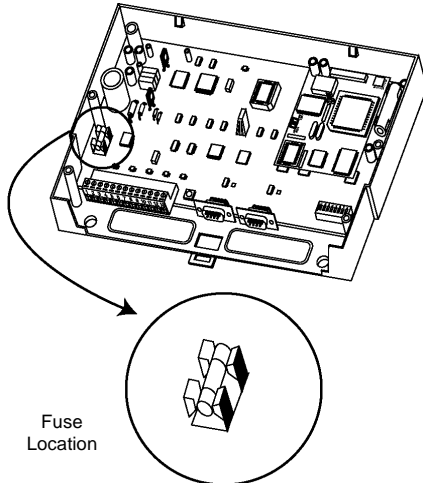

## DIMENSION DRAWING

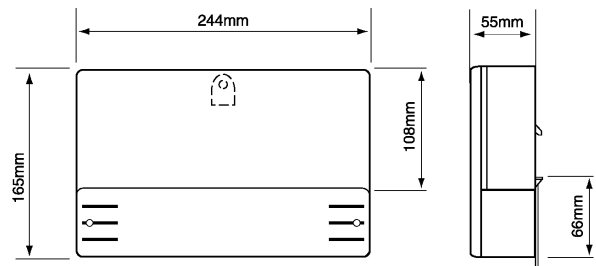

Dimensions in mm

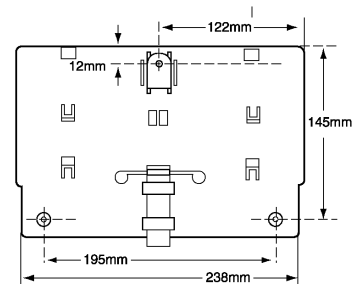

Weights:

MN MI	approx. 890g
Router	approx. 890g
MNA-C Card	18.3g

## Battery Replacement

### WARNING -

**THE LITHIUM CHLORIDE BATTERY IS COMPLETELY SAFE WHILST IN NORMAL USE. THE BATTERY MUST BE DISPOSED OF IN ACCORDANCE WITH LOCAL WASTE REGULATIONS.**

Should there be a power failure, the clock and RAM are protected with a battery-backup. Do the following to check and replace battery:

Caution: All clock functions and data stored in RAM will be lost with power turned OFF and battery removed (MN MIs).

1. Turn OFF power to the device.
2. Remove cover.
3. Remove battery.
4. Check battery.
5. If battery is faulty, replace battery with same type and rating. (Part number E17-129, 3.6V AA Non-rechargeable lithium.)
6. Re-install cover.
7. Turn ON power to the device.
8. Dispose of battery properly.

### WARNING -

**THE BOARD CONTAINS A LITHIUM CHLORIDE BATTERY WHICH IS COMPLETELY SAFE WHILST IN NORMAL USE. THE BATTERY MUST BE DISPOSED OF IN ACCORDANCE WITH LOCAL WASTE REGULATIONS.**

- Do not apply any voltages until a qualified technician has checked the system and the commissioning procedures have been completed.
- This is a 24Vac device. Do not exceed rated voltage. Local wiring regulations and usual safety precautions apply.
- 24Vac must be supplied by a transformer conforming to EN 61558.
- If any equipment covers have to be removed during the installation of this equipment, ensure that they are refitted after installation to comply with UL and CE safety requirements.
- Do not exceed the maximum ambient temperature.
- Interference with parts under sealed covers invalidates guarantee.
- The design and performance of TAC Satchwell equipment is subject to improvement and therefore liable to alteration without notice.
- Information is given for guidance only and TAC Satchwell does not accept responsibility for the selection or installation of its products unless information is given by the Company, in writing, relating to a specific application.
- A periodic system and tuning check of the control system is recommended.

Copyright © 2006, TAC AB  
All brand names, trademarks and registered trademarks are the property of their respective owners. Information contained within this document is subject to change without notice. All rights reserved.

DS 10.217A 12/06



**TAC Headquarters**  
Malmö, Sweden  
+46 40 38 68 50

**Satchwell Helpline**  
+44 (0) 1753 611000  
satchwell.info@uk.tac.com

[www.tac.com](http://www.tac.com)

