



VAV system solution for non-pressure-dependent applications in enclosed spaces

Table of contents

Technical data sheet

Brief description	3
Technical data	4
Safety notes	5
Dimensions	5
Operation, setup, connections	6
Electrical connections	7

Funktionen

Nominal volumetric flow \dot{V}_{nom}	8
Operating volumetric flow, $\dot{V}_{min} \dots \dot{V}_{max}$	8
VAV application	8
VAV voltage level	8
VAV operation	8
CAV application	9
Control	9
Priorities input w / Z1 / Z2	9
$\dot{V}_{min} / \dot{V}_{max}$ setting [Potentiometer or Tool (PP Command)]	9

Setting with VAV adjustment tool ZTH-VAV	10
--	----

Actuator variants / VAV adjustment tool ZTH-VAV	11
---	----

Plug-ready VAV-Universal system solution with integrated, almost static Belimo D3 pressure sensor for non-pressure-dependent VAV and CAV applications in enclosed spaces.

Control:

DC 2 ... 10 V / 0 ... 10 V / contacts

Settings:

- at the controller \dot{V}_{\min} / \dot{V}_{\max} or
- with VAV adjustment tool ZTH-VAV

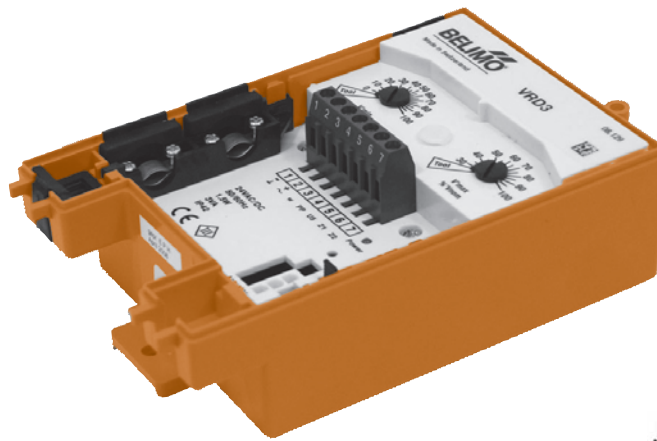

Brief description

Application	The digital VAV-Universal solution VRD3 with its PI control characteristics is used for pressure-independent control of VAV units in the comfort zone.
Pressure measurement	The integrated maintenance-free Belimo D3 differential pressure sensor allows a variety of applications ranging from offices, hospitals and hotels all the way to cruise ships.
Actuator	<p>The following actuator models are available, depending on the area of application, size and structural shape of the VAV unit:</p> <ul style="list-style-type: none"> – Rotary actuator 0 ... 95°↔, depending on the size 5, 10, 20 Nm – Rotary actuator 0 ... 95°↔ with safety position current-free CLOSED or OPEN, 4 or 15 Nm – Rotary actuator 0 ... 1800°↔ e.g. for iris dampers 3 Nm – Linear actuation 100, 200 or 300 mm linear motion, 150 N
Control function:	VAV or CAV operation
Bus mode	The utilisation of the VRD3 in MP-Bus systems (UK24LON, Fan Optimiser COU24-A-MP, etc.) is not possible. The VAV-Compact series and the VAV-Universal VRP-M system solution is available for these bus applications.
VAV – variable air volume	For variable air volume applications based on a modulating reference variable, e.g. supplied by a room temperature controller or a DDC system; it facilitates demand-related, power-saving ventilation in individual rooms or in zones of air conditioning systems. The \dot{V}_{\min} ... \dot{V}_{\max} working range can be subdivided by selecting a mode. Available are the following: DC 2 ... 10 / 0 ... 10 V.
CAV – constant volume flow	For constant air volume applications, e.g. in step mode, controlled by means of an occupancy switch. The following operating modes are available: CLOSED / \dot{V}_{\min} / \dot{V}_{\max} / OPEN
Function indication	Functional readiness display with green LED.
Operating and service devices	<ul style="list-style-type: none"> • VAV adjustment and diagnostics device ZTH-VAV: pluggable at the service socket of the VRD3 or at the PP interface (terminal 4). • Belimo PC-Tool: cannot be used with the VRD3
Assembly and connection	The connection is made by screw terminal. The actuator is connected with a plug-ready, pre-assembled cable.
OEM factory settings	The VRD3 system solution is mounted on the VAV unit by the unit manufacturer, who adjusts and tests it according to the application. The VRD3 solution is sold exclusively through the OEM channel for this reason.

Technical data

Supply

Nominal voltage	AC 24 V, 50 / 60 Hz / DC 24 V
Nominal voltage range	AC 19.2 ... 28.8 V / DC 21.6 ... 28.8 V
Power consumption	2 W / 3.5 VA, without actuator

Differential pressure sensor, installed

Type, principle of operation	Belimo D3-Sensor, Dynamic with almost static behaviour
Operating range	For VRD3 application: 2 ... 300 Pa
Overload capability	±3000 Pa
Installation position	Non-position-dependent, no zero-point compensation necessary
Materials in contact with medium	Glass, epoxy resin, PA, TPE

Control function:

Control function	VAV and CAV units
Application	– Single duct installations – Supply / exhaust air units – Dual duct installations – Mixed units
Pressure range	2 ... 300 Pa

Max. system primary pressure	≤1000 Pa >1000 ... 1500 Pa	<i>Information for VAV unit manufacturer:</i> ΔP @ \dot{V}_{nom} : useful adjusting range 50 ... 300 Pa ΔP @ \dot{V}_{nom} : useful adjusting range 150 ... 300 Pa
Characterising	VAV units, OEM-independent, with linearization to match the differential pressure sensor	
Medium	Supply and exhaust air in the comfort zone and in applications with sensor-compatible media	
Measuring air conditions	0 ... +50°C / 5 ... 90% r.H., non-condensating	

Operating volumetric flow

\dot{V}_{nom}	OEM-specific nominal volumetric flow setting, suitable for the VAV unit	
\dot{V}_{max}	30 ... 100% of \dot{V}_{nom}	
\dot{V}_{min}	0 ... 100% of \dot{V}_{nom}	

VAV – input w, terminal 3	Switch-selectable VRD3 ↔ VRD2 (compatible with predecessor model, see page 4)	
Mode DC 2 ... 10 V	\dot{V}_{min} ... \dot{V}_{max} , CLOSED with activation <0.1 V	(see pg. 5 ... 7)
Mode DC 0 ... 10 V	\dot{V}_{min} ... \dot{V}_{max}	
Input impedance	~100 kΩ	

CAV – input w, terminal 3	– Compatible with L/N/SMV-D2M-MP – Operating stages CLOSED, \dot{V}_{min} , \dot{V}_{max} , OPEN	(see pg. 5 ... 7)
----------------------------------	---	-------------------

Override – input Z1 / Z2	Requires AC 24 V power supply
Z1 – terminal 6	OPEN
Z2 – terminal 7	CLOSED, \dot{V}_{min} , \dot{V}_{max}

Actual volumetric flow signal [U5] – terminal 5	– DC 2 ... 10 / 0 ... 10 V for 0 ... 100% \dot{V}_{nom} – Max. load 0.5 mA
--	---

Operating

local	Potentiometer for \dot{V}_{min} / \dot{V}_{max} setting
Tool	VAV adjustment tool ZTH-VAV, connection via service plug or PP connection

Actuator (...V models)

5 / 10 / 20 Nm, depending on application	– Direction of rotation (l / r or ↑ / ↓)	(see pg. 10)
Connection can be plugged into VRD3	– Angle of rotation limitation or stroke limitation – Adaption, adjusting range modification and/or resolution to control range – Manual disengagement	
Sound power level	– Max. 35 dB(A), SM24A-V max. 45 dB(A) – LF24-A-V Motor max. 35 dB(A), spring ≈ 62 dB(A), AF24-V Motor max. 35 dB(A), spring ≈ 62 dB(A)	
Damper rotation	Clamp, for axle round / square or positive fit e.g. 8 x 8 mm	

Connection

Supply and control	7-pin screw terminals for 2 x 1.5 mm ²
Tool connection	RJ12 socket
Actuator	3-pin plug for ...V actuator

Safety

Protection class	III Safety extra-low voltage
Degree of protection	IP40
EMC	CE according to 2004/108/EC
Mode of operation	Type 1 (EN 60730-1)
Rated impulse voltage	0.8 kV (EN 60730-1)

Technical data
(continued)
environment conditions

Control pollution degree	2 (EN 60730-1)
Ambient temperature	0 ... 50 °C
Non-operating temperature	-20 ... +80 °C
Ambient humidity	95% r.H., non-condensating (EN 60730-1)
Maintenance	Maintenance-free

Dimensions / Weight

Dimensions	See «Dimensions» on page 3
Weight	Approx. 440 g

Safety notes

- The VRD3 system solution is not allowed to be used outside the specified field of application, especially in aircraft or any other form of air transport.
- Assembly must be carried out by trained personnel. Any legal regulations or regulations issued by authorities must be observed during assembly.
- The device does not contain any parts that can be replaced or repaired by the user.
- The cable must not be removed from the actuator.
- The device contains electrical and electronic components and is not allowed to be disposed of as household refuse. All locally valid regulations and requirements must be observed.

Dimensions [mm]

Dimensional drawings
(For actuators, see separate data sheets)

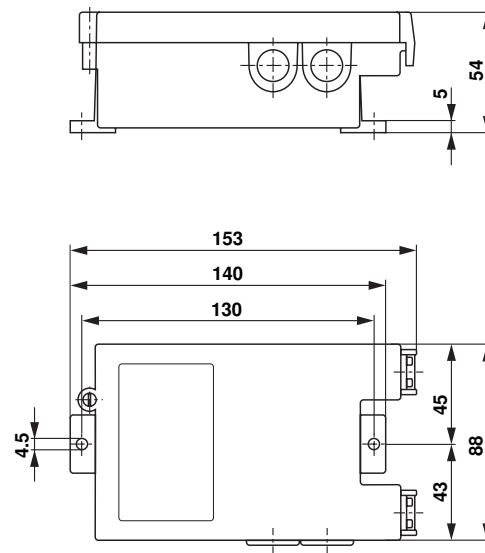
Compatibility VRD3 ↔ VRD2

The VRD3 corresponds in its dimensions and connections to the VRD2.

Operation, setup, connections

Setup, connections

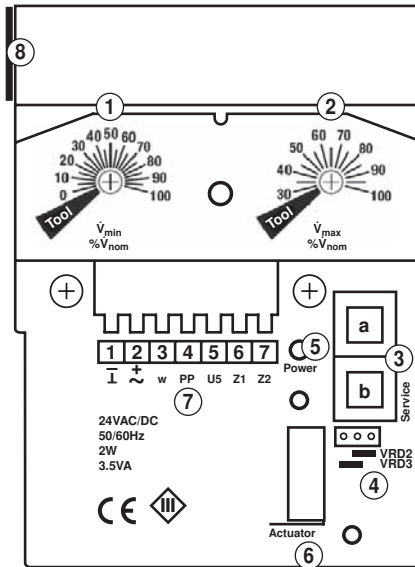

①	Operating volumetric flow setting \dot{V}_{min} 0 ... 100% [in % of \dot{V}_{nom}]
②	Operating volumetric flow setting \dot{V}_{max} 30 ... 100% [in % of \dot{V}_{nom}]
③	Tool connection a System plug: internal Belimo function, not for users b Service: connection for VAV adjustment tool ZTH-VAV
④	Jumper for input w (terminal 3) Function: – VRD2: VRD2-compatible – VRD3: VRD3 and L/N/SMV-D2-MP
⑤	Power LED , Function display 24 V
⑥	Connection for V-actuator
⑦	Connecting terminals 1 ... 7
⑧	Connection D3 Sensor

Connecting terminals 1 ... 7

Terminal	Designation	Function
1	$\perp / -$	Supply AC/DC 24 V
2	$\sim / +$	
3	w	Reference value input w jumper VRD3 – Mode 0 ... 10 / 2 ... 10 V switchable with ZTH-VAV – Function as with new VAV-Compact L/N/SMV-D2-MP: VAV: 0 ... 10 / 2 ... 10 V = \dot{V}_{min} ... \dot{V}_{max} CAV: CLOSED / \dot{V}_{min} / \dot{V}_{max} / OPEN Reference value input w jumper VRD2 – Mode 0 ... 10 / 2 ... 10 V switchable with ZTH-VAV – Function as with VRD2: VAV: 0 ... 10 / 2 ... 10 V = \dot{V}_{min} ... \dot{V}_{max} CAV: not possible use Z1 / Z2
4	PP	PP interface for ZTH-VAV (no MP operation)
5	U5	Actual volumetric flow signal U5 – Mode 0 ... 10 / 2 ... 10 V switchable with ZTH-VAV – Display range 0 ... 100% \dot{V}_{nom}
6	Z1	Override input Z1: Function OPEN
7	Z2	Forced control input Z2: function CLOSED / \dot{V}_{min} / \dot{V}_{max}

Note

- Supply via safety isolation transformer!
- It is recommended that the PP connection (terminal 4) and the 24 V be wired to readily accessible terminals in order to guarantee easy access with the VAV adjustment tool ZTH-VAV (e.t. at the room temperature controller CR24 or in the control cabinet).

The VRD3 does not support any MP operation!

Electrical connections

Wiring diagrams

Connection VRD3

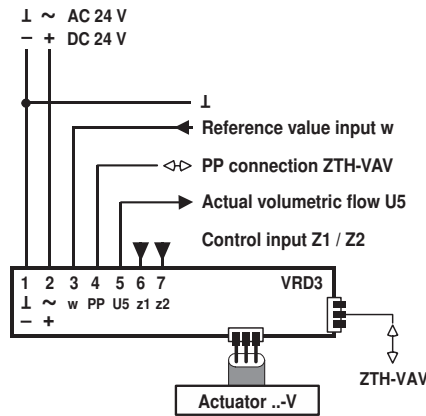

VAV connection: supply and exhaust air system

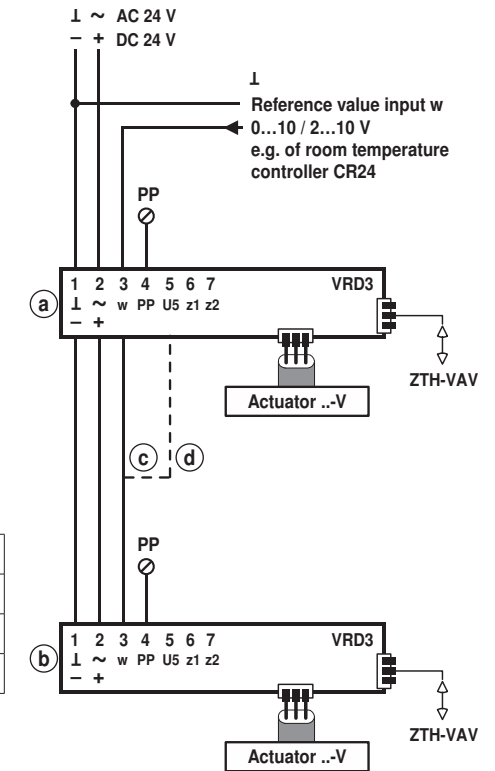

Compatibility VRD3 ↔ VRD2:

- **Reference signal [w] (terminal 3)**
Plugging the jumper in at position «VRD2» causes the VRD3 to behave like the predecessor model VRD2 (i.e. no CAV control function via input w).
- **Forced control inputs Z1 (terminal 6) and Z2 (terminal 7) are functionally compatible with the VRD2** and are not influenced by the jumper.
- **Tool connection PP (terminal 4)**
The VRD3 is equipped with a separate tool connection PP (terminal 4). For the VRD2, the tool connection is made via terminal 5, which exhibits a combination function: volumetric flow actual value signal U5 and PP connection.

CAV connection

Connection Z1 / Z2

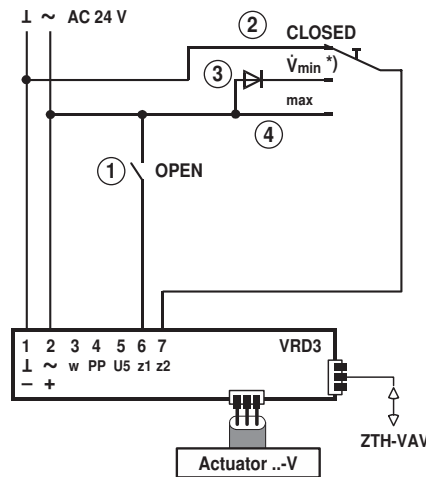

Connection input w

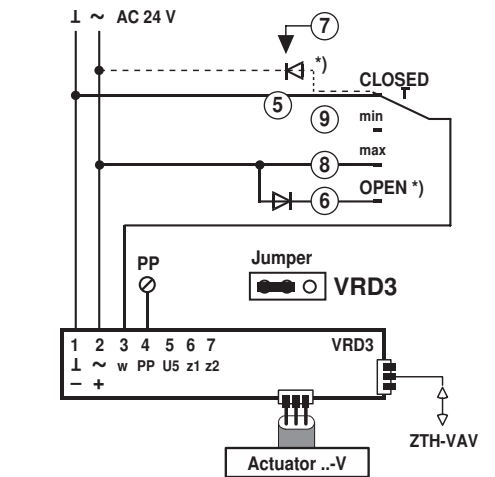

Note:

The input signals 3 (w), 6 (Z1) and 7 (Z2) of several VRD3s can be switched with a joint signal, e.g. CLOSED. It is not permitted to switch connection 6 (Z1) with a VRD2 terminal 6.

Overview control signals / Functions

Signal terminal / Function	Priority	GND	pos. hydraulic switch	neg. hydraulic switch	24 VAC	open
Forced input Z1 – terminal 6	1	–	OPEN (1)	–	OPEN (1)	–
Forced input Z2 – terminal 7	2	CLOSED (2)	\dot{V}_{min} (3)	–	\dot{V}_{max} (4)	–
Tool (PP-Cmd) → ZTH-VAV	3	CAV stages (Auto, CLOSED, OPEN, \dot{V}_{min} , \dot{V}_{max} , Stop)				
Reference signal w – terminal 3 Jumper: VRD3	4	CLOSED (5) Mode: 2 ... 10 V	OPEN (6)	CLOSED (7) Mode: 0 ... 10 V	\dot{V}_{max} (8)	\dot{V}_{min} (9)

Note:

*) CAV control applications requires AC 24 V power supply.

Functions

Nominal volumetric flow \dot{V}_{nom} \dot{V}_{nom} corresponds to the maximum volumetric flow of the VAV unit at which the pressure drop and noise are still within the permissible operating conditions. The \dot{V}_{nom} values are defined by the unit manufacturer for all unit nominal values; the VRD3 controller is calibrated by the OEM to this flow rate.
The volumetric flow actual value signal U5 is always in relation to the \dot{V}_{nom} . Modifications of the operating volumetric flow settings \dot{V}_{min} and \dot{V}_{max} have therefore no influence on the U5 volt signal.

Operating volumetric flow, $\dot{V}_{min} \dots \dot{V}_{max}$ In variable operation, the volumetric flow is specified by means of the reference signal in the range $\dot{V}_{min} \dots \dot{V}_{max}$.
– \dot{V}_{max} forms the upper limit value. Adjustment range 30 ... 100% of \dot{V}_{nom} .
– \dot{V}_{min} forms the lower limit value. Adjustment range 0 ... 100% of \dot{V}_{nom} .

The \dot{V}_{max} value must always be set higher than the \dot{V}_{min} value; otherwise the VRD3 controller will operate with the \dot{V}_{min} volume as setpoint in CAV mode.

See also Note 1) below. For $\dot{V}_{min} / \dot{V}_{max}$ setting, see page 8

VAV application In VAV operation, the regulated amount of air $\dot{V}_{min} \dots \dot{V}_{max}$ is specified via an analogue reference signal, e.g. from a 2 ... 10 V room temperature controller.

Example: Mode 0 ... 10 V

Reference signal w

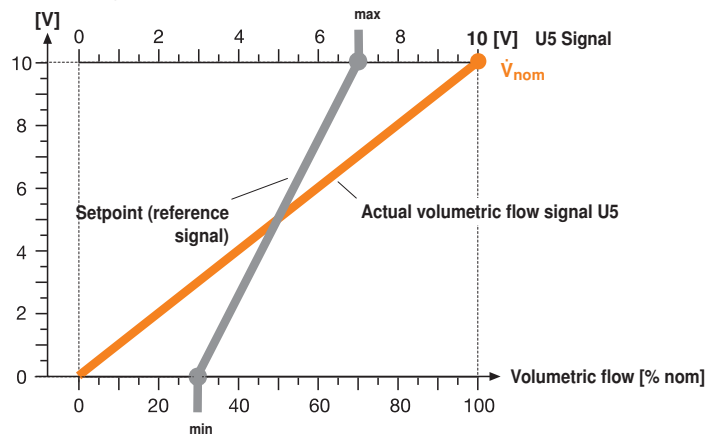

VAV voltage level

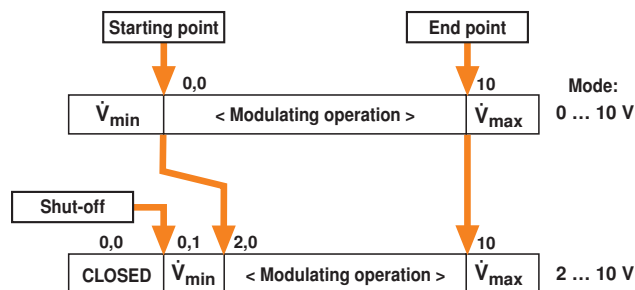

VAV operation

• With «Damper CLOSED» option

In mode 2 ... 10 V, it is possible to achieve shut-off mode (damper CLOSED) by lowering the reference signal to 0.0 V.

• With superordinate override controls

For forced control input during VAV operation, e.g. CLOSED or OPEN, the reference signal w (input 3) can be overridden by switching the control inputs 6 (Z1) and 7 (Z2).

1) Note concerning difference \dot{V}_{min} setting VRD3, VRD2

The adjustment range of the operating mode \dot{V}_{min} with:

- VRD2 refers to 0 ... 100% of \dot{V}_{max}
- VRD3 refers to 0 ... 100% of \dot{V}_{nom}

The \dot{V}_{min} setting of the VRD3 thus behaves in compatible fashion with the new VAV generation (starting with 2006), i.e. VAV-Compact L/N/SMV-D2-MP, VRP-M.

Functions

(continued)

CAV application

Four constant volumetric flow (CAV) stages are available for step mode:
 – Shut-off operation – damper CLOSED: the damper is moved to CLOSED.
 – CAV stages \dot{V}_{min} / \dot{V}_{max} : the VRD3 controls the selected volumetric flow at a fixed value.
 – Flushing operation – damper OPEN: The damper can be opened for maximum ventilation, in which case air volume control is deactivated.
 The operating mode control signals are connected to inputs 6 (Z1) and 7 (Z2). If signals appear at these two inputs simultaneously, input 6 (Z1) for the OPEN function takes priority.

Control

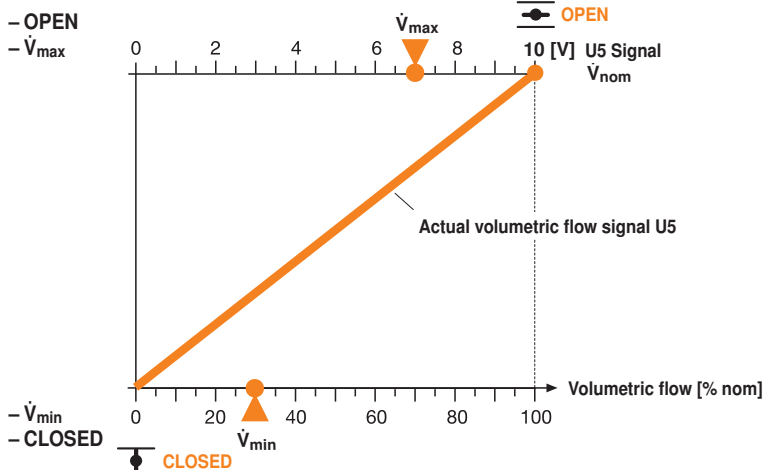

Priorities input w / Z1 / Z2

Prio 1:	Z1 (terminal 6)
Prio 2:	Z2 (terminal 7)
Prio 3:	VAV adjustment tool ZTH-VAV (PP command)
Prio 4:	Reference signal w (terminal 3)

\dot{V}_{min} / \dot{V}_{max} setting
 [Potentiometer or Tool (PP Command)]

Die operating volumetric flow settings \dot{V}_{min} and \dot{V}_{max} can be adjusted two different ways on the VRD3:

- a) directly on the adjustment potentiometer (analogous to the VRD2)
 - \dot{V}_{min} 0 ... 100% of \dot{V}_{nom}
 - \dot{V}_{max} 30 ... 100% of \dot{V}_{nom}
- b) with VAV adjustment tool ZTH-VAV (PP command)

Both of the potentiometers \dot{V}_{min} and \dot{V}_{max} must be set to Tool position in order to write a value – with PP Command – in the VRD3. If the potentiometer(s) are set to «Tool» with connected ZTH-VAV, then the menu will need to be refreshed under certain circumstances by actuating the keys $\uparrow \downarrow$. For function, see following illustration:

Adjustment potentiometer \dot{V}_{min} / \dot{V}_{max}

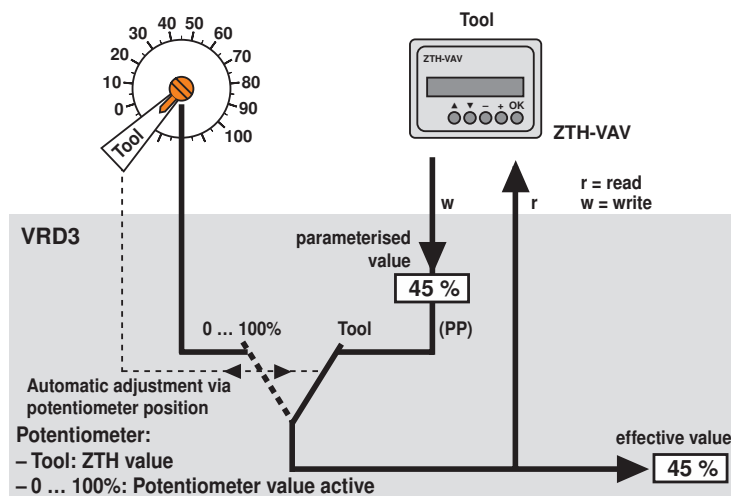

Note concerning difference \dot{V}_{min} setting VRD3, VRD2

The adjustment range of the operating mode \dot{V}_{min} with:
 – VRD2 refers to 0 ... 100% of \dot{V}_{max}
 – VRD3 refers to 0 ... 100% of \dot{V}_{nom}
 The \dot{V}_{min} setting of the VRD3 thus behaves in compatible fashion with the new VAV generation (starting with 2006), i.e. VAV-Compact L/N/SMV-D2-MP, VRP-M.

The \dot{V}_{max} value must always be set higher than the \dot{V}_{min} value; otherwise the VRD3 controller will operate with the \dot{V}_{min} volume as setpoint in CAV mode.

Setting with VAV adjustment tool ZTH-VAV

The entire BELIMO product range with PP connection can be set and controlled with the VAV adjustment tool ZTH-VAV. The connection to the VRD3 is provided by the RJ «Service» socket or at the PP connection (terminal 4), e.g. in the control cabinet.

Operating menu VRD3

Option	Unit	Range / setting	Function
Volumetric flow – actual value	%	0 ... 100% [of \dot{V}_{nom}]	Commissioning, Service function
Volumetric flow - setpoint	%	0 ... 100% [\dot{V}_{min} ... \dot{V}_{max}]	
Current effective pressure *	Pa	0 ... 300 Pa	
Specify CAV steps	–	Auto – CLOSED – OPEN – – \dot{V}_{min} – \dot{V}_{max} – Stop	
Mode	–	0 ... 10 V, 2 ... 10 V	
\dot{V}_{min} . setting	%	0 ... 100% [of \dot{V}_{nom}]	Settings, modifications
\dot{V}_{max} . setting	%	30 ... 100% [of \dot{V}_{nom}]	
\dot{V}_{nom} VAV unit	%	Nominal setting = 100%	OEM setting
$\Delta p @ \dot{V}_{nom}$ *	Pa	differential pressure pending with \dot{V}_{nom}	

* Option requires ZTH-VAV firmware V1.02 or higher (06.2008).
See also Release Note ZTH-VAV, www.belimo.eu.

Specify CAV steps

The VRD3 – with the ZTH-VAV – can be switched to one of the CAV stages illustrated below for functional checking of the VAV / CAV units.

Stage	Function	Control function:
AUTO *	Setpoint of input w, terminal 3 or 6 / 7.	VAV or CAV operation
CLOSED	Damper closes	no control mode
OPEN	Damper opens	no control mode
\dot{V}_{min}	Controller travels volumetric flow \dot{V}_{min}	CAV operation \dot{V}_{min}
\dot{V}_{max}	Controller travels volumetric flow \dot{V}_{max}	CAV operation \dot{V}_{max}
STOP	Damper stops on current position	no control mode

* If the ZTH-VAV has been disconnected from the VRD3 without reactivation of the «Auto» stage, then the VRD3 will be reset to automatic operation after max. 120 s.

Connection



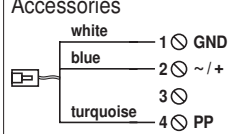

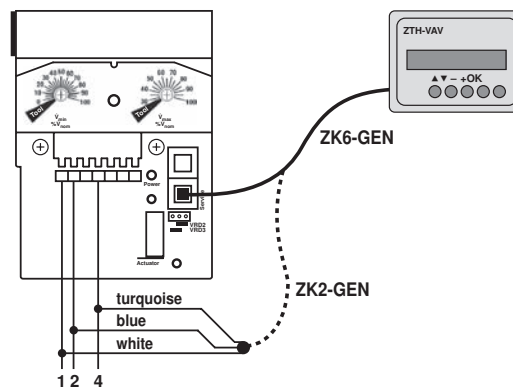

Connection to	Cable type and order designation
VRD3, RJ «Service» socket	ZK6-GEN Accessories
PP connection (terminal 4), e.g. control cabinet terminals	ZK2-GEN Accessories



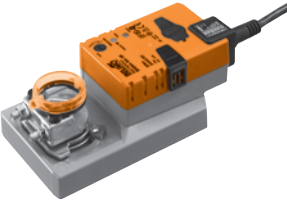

For detailed documentation concerning the handling and function of the ZTH-VAV, see ZTH-VAV instruction manual at www.belimo.eu

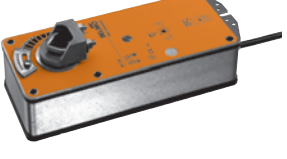
Actuator variants (standard actuators)

	Type	Actuator	Features
Rotary actuators 0 ... 90°↔	LM24A-V		<ul style="list-style-type: none"> - Damper actuator for VAV-Universal - AC/DC 24 V, modulating, 5 Nm - Control DC 6.0 ±4 V from VRD3 controller - Motor running time 110 ... 150 s - Connection: cable with plug - Angle of rotation 90°↔
	NM24A-V		<ul style="list-style-type: none"> - Damper actuator for VAV-Universal - AC/DC 24 V, modulating, 10 Nm - Control DC 6.0 ±4 V from VRD3 controller - Motor running time 120 s - Connection: cable with plug - Angle of rotation 90°↔
	SM24A-V		<ul style="list-style-type: none"> - Damper actuator for VAV-Universal - AC/DC 24 V, modulating, 20 Nm - Control DC 6.0 ±4 V from VRD3 controller - Motor running time 120 s - Connection: cable with plug - Angle of rotation 90°↔
Spring-return actuators 0 ... 90°↔	LF24-V		<ul style="list-style-type: none"> - Spring-return actuator for VAV-Universal - AC/DC 24 V, modulating, 4 Nm - Control DC 6.0 ±4 V from VRD3 controller - Running time motor 120...300 s - Running time spring-return approximately 20 s - Connection: cable with plug - Angle of rotation 95°↔
	AF24-V		<ul style="list-style-type: none"> - Spring-return actuator for VAV-Universal - AC/DC 24 V, modulating, 15 Nm - Control DC 6.0 ±4 V from VRD3 controller - Running time motor 120...300 s - Running time spring-return approximately 16 s - Connection: cable with plug - Angle of rotation 95°↔
Actuators* for special applications	* LU24A-..		<ul style="list-style-type: none"> - Rotary actuator 0 ... 1800°↔ rotating, e.g. for iris dampers 3 Nm
	* LH24A-..		<ul style="list-style-type: none"> - Linear actuation 100, 200 oder 300 mm linear motion, 150 Nm

* on request

VAV adjustment tool ZTH-VAV

ZTH-VAV		<ul style="list-style-type: none"> - Adjustment tool for Belimo VAV controller - Supply to VAV controller AC/DC 24 V
---------	---	--

For more detailed documents, see www.belimo.eu

All inclusive.



5 years
Guarantee



Worldwide
present



Complete
assortment from
a single source



Examined
Quality



Short
delivery time



Comprehensive
support

Headquarters

BELIMO Holding AG
Brunnenbachstrasse 1
CH-8340 Hinwil
Tel. +41 (0)43 843 61 11
Fax +41 (0)43 843 62 68
info@belimo.ch
www.belimo.com

Subsidiaries, Representatives and Agencies

Argentina
Australia
Bahrain
Belgium
Bosnia-Herzegovina
Brazil
Bulgaria
Canada
Chile
Croatia
Cyprus
Czech Republic

Denmark
Egypt
Estonia
Finland
France
Great Britain
Germany
Greece
Hong Kong
Hungary
Iceland
India
Indonesia
Ireland
Israel
Italy
Japan
Jordan
Kuwait
Latvia

Lebanon
Liechtenstein
Lithuania
Luxembourg
Malaysia
Mexico
Morocco
Netherlands
New Zealand
Norway
Oman
Pakistan
People's Republic of China
Philippines
Poland
Portugal
Qatar
Republic of Korea (South Korea)

Rumania
Russia
Saudi Arabia
Singapore
Slovakia
Slovenia
South Africa
Spain
Sweden
Switzerland
Taiwan
Turkey
Ukraine
United Arab Emirates
United States of America