



ET45 TEMPERATURE CONTROLLER



GENERAL DESCRIPTION

The ET45 is a compact Electronic Temperature controller designed for universal application in the air conditioning industry. The controller has four relay outputs, relays one and two are configured for two stage heating and relays three and four are configured for two stage cooling. In addition to the relay outputs, there is a Direct Acting (DA) 0 - 10 vdc signal, a Reverse Acting (RA) 0 - 10 vdc signal, which can be used for economy cycles, modulating heat or cooling valves, control signals to VAVs, etc.

FEATURES

Wide temperature range 10 - 35°C u Analog signals (0 - 10 vdc) for both heating and cooling. Australian made and supported u All adjustments external to enclosure. Remote Setpoint adjustment option u 240 vac power supply. Time Proportional electric heater control u Terminal covers supplied as standard. Simplified Reverse Cycle unit control u 30 second delay switch on, no delay off.

The ET45 controller is designed to be DIN rail mounted in a switchboard, however, with its compact size of 105mm by 105mm, it is small enough to be mounted in the unit, if required. The controller has two rows of terminals. The top row of terminals are low voltage and have the connections for the remote sensor, remote setpoint, and the two analog outputs. The lower row of terminals are used for the 240 vac power connection (terminals 17 and 18), and also the four relay outputs, which are voltage free. The front fascia of the controller has the internal setpoint of 10 - 35°C located on it, as well as the four LEDs which indicate the status of the relays.

DIP SWITCHES

There are three DIP switches on the top right hand side of the controller. These switches are used to configure the controller to a number of different control modes.

Dip Switch 1 (Remote Setpoint)

This switch is moved to the right (external setpoint) when a remote setpoint adjuster is connected. The dip switch disconnects the internal setpoint on the fascia and permits temperature adjustment from a remote location.

Dip Switch 2 (Reverse Cycle Operation)

This switch is moved to the right when the air conditioning unit is of the type that has compressor and reversing valve control inputs. The simplified connection enables the reversing valve to be connected to the H1 output and the compressors be connected to C1 and C2 outputs as required. The H1 output is automatically changed to maintain the controller in the reverse cycle mode until the temperature in the space rises above setpoint. C1 and C2 will operate in the cooling and heating mode. H2 does not operate on reverse cycle operation.

Dip Switch 3 (Time Proportional Electric Heat)

This switch is moved to the right when it is required to proportionally control electric heaters. The duty cycle is approximately 100 seconds and the control relay (H1/H2) cycles on and off in response to the variation in temperature below the setpoint. For instance, if half the heater capacity of one stage is required, the heater contactor is energised for 50 seconds then deenergised for 50 seconds. Both H1 and H2 are controlled on a time proportional basis when dip switch 3 is switched to the right.



Regulator Systems

MANUFACTURER OF AIR CONDITIONING CONTROLS AND INSTRUMENTATION

ET45 TEMPERATURE CONTROLLER

TECHNICAL CONNECTION DIAGRAM

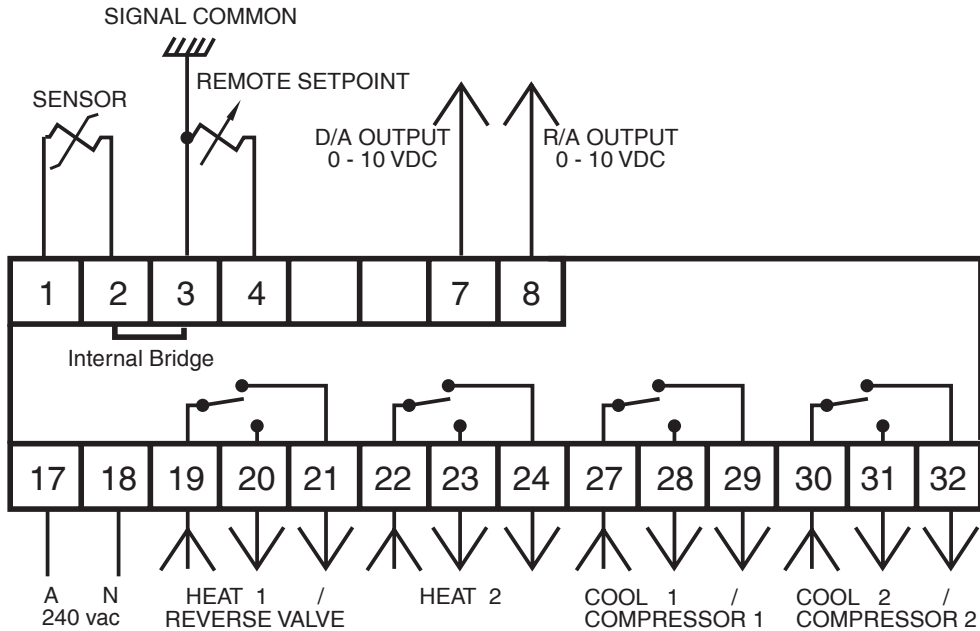

DIMENSIONS

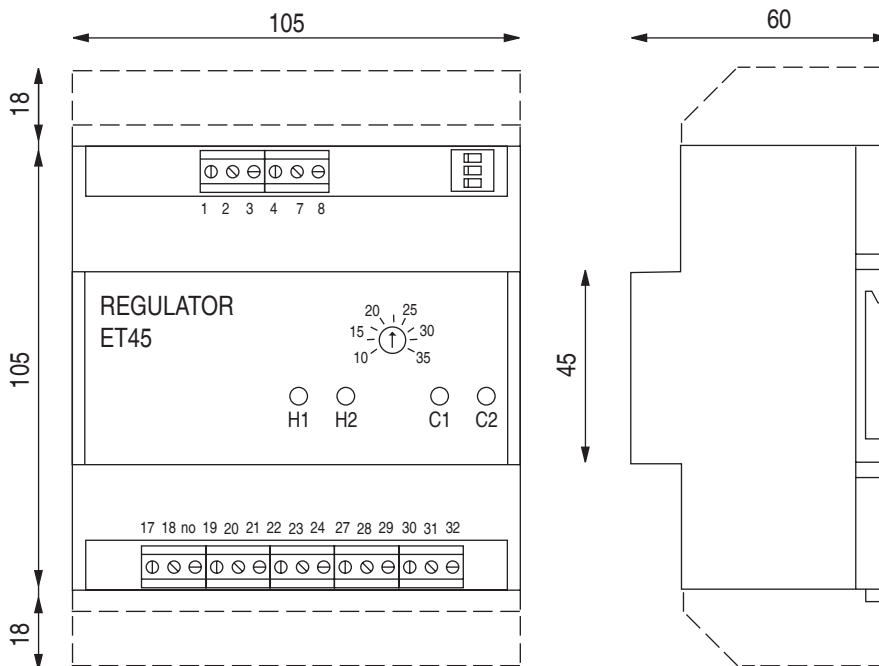

dotted line indicates terminal covers



ET45 TEMPERATURE CONTROLLER

APPLICATIONS

2 STAGE ELECTRIC HEAT WITH 2 STAGE COOL

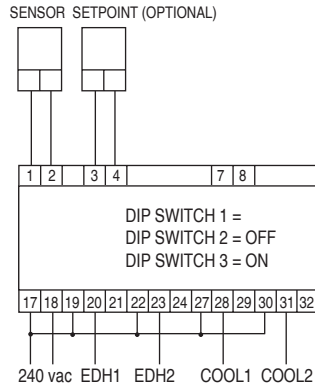

2 STAGE REVERSE CYCLE

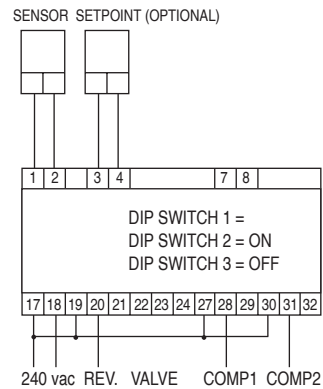

2 STAGE REVERSE CYCLE WITH ECONOMY CYCLE

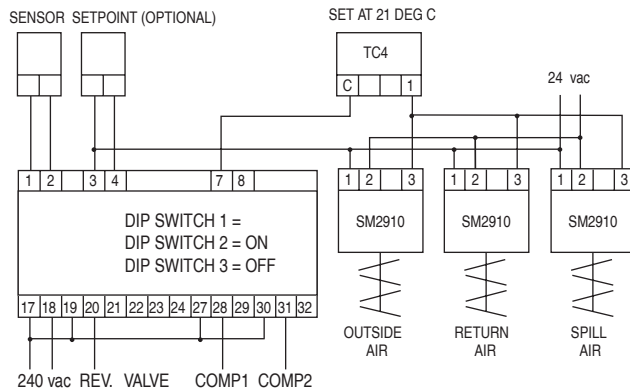

TECHNICAL DATA

Supply Voltage	240 vac +/- 10%
Supply Frequency	50 / 60 Hz
Power Consumption	1.2 VA
Ambient Temperature operating	0 - 50°C
Ambient Temperature storage	-20 - 60°C
Ambient Humidity	Max 90% RH
Size	H: 105mm W: 105mm D: 60mm
Weight	0.3kg
Input Sensor NTC Thermistor	2 K ohms @ 25°C
Setpoint Range 1	0 - 35°C
Remote Setpoint Supply	0.5 mA constant current source
D/A and R/A Output Voltages	0 - 10 vdc @ 10 mA max

Proportional Band	5 volts per °C
Relay Outputs Voltage free contacts	250 vac
Relay Contact Rating	5 amps resistive
Control Circuit Fusing	5 A max
First Stage Cool Pull in Voltage	5 volts D/A (+1.0C)
Second Stage Cool Pull in Voltage	7.5 volts D/A (+1.5C)
First Stage Heat Pull in Voltage	5 volts R/A (-1.0C)
Second Stage Heat Pull in Voltage	7.5 volts R/A (-1.5C)
Differential	2.5 volts (0.5C)
H1 Pull in Voltage on Reverse Cycle	2.5 volts (0.5C)
H1 Drop out Voltage on Reverse Cycle	1.25 volts (0.25C)