



# Regulator Systems

MANUFACTURER OF AIR CONDITIONING CONTROLS AND INSTRUMENTATION

## TC2000 TEMPERATURE CONTROLLER



### FRONT PANEL

#### Digital Display & Display Selector Switch

- The Display Selector Switch has five positions:
- 1 TEMP °C Displays the sensor temperature with 0.1°C resolution from -40°C to +100°C.
  - 2 INT S.P. Displays the INTERNAL SETPOINT to which the controller is working from -40°C to 100°C.
  - 3 EXT S.P. Displays the remote setpoint when the external setpoint is installed and the INT EXT switch is set to EXT; standard remote setpoints are 10 - 35°C and 18 - 28°C.
  - 4 D/A Displays the 0-10VDC signal generated when the temperature is ABOVE the setpoint selected.
  - 5 R/A Displays the 0-10VDC signal generated when the temperature is BELOW the setpoint selected.

#### Relay Setpoints & LED Display

The operation of the relay stages in the system are indicated by the respective LED's and controlled by the potentiometers immediately below the digital display. The pull in volts is set by the left potentiometer and the differential by the right potentiometer. When the relay is energised the LED is illuminated. The zero volts drop out feature prevents any relay from locking on if the differential voltage is set higher than the pull in volts. The internal circuitry will drop out the relay at 100mV. (The settings on the differential are in volts not in percentage of pull in volts.)

#### Sensor Fault & Setpoint Selection & Adjustment

At the lower left is the sensor fault light to indicate when a fault is detected and shutdown is effected. A setpoint adjustment screw is located to the right of the sensor LED and a switch to select internal or external setpoint is located below.

### SYSTEM 2000

SYSTEM 2000 is totally Australian designed and manufactured. Exclusive circuitry gives the TC2000 Temperature Controller all the features that has made this system an industry leader. The TC2000 is part of the system 2000 control devices developed by Regulator Australia. The basic features common to all the 2000 series controllers create a uniquely flexible yet powerful configuration. With all the functions that create an accurate and reliable controller housed in the one unit, the TC2000 offers the finger-tip control needed for complex conditions.

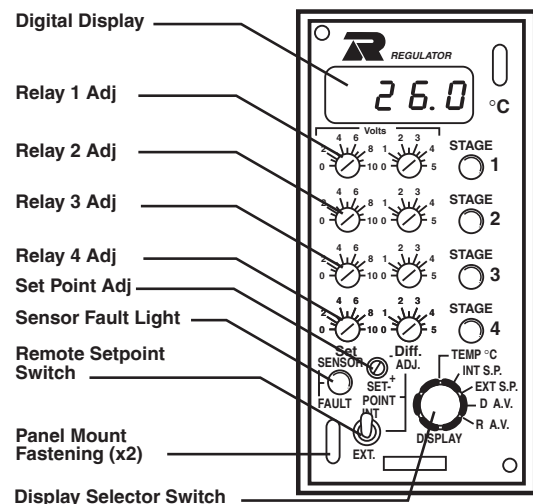



# Regulator Systems

MANUFACTURER OF AIR CONDITIONING CONTROLS AND INSTRUMENTATION

## TC2000 TEMPERATURE CONTROLLER

### INTERNAL LAYOUT

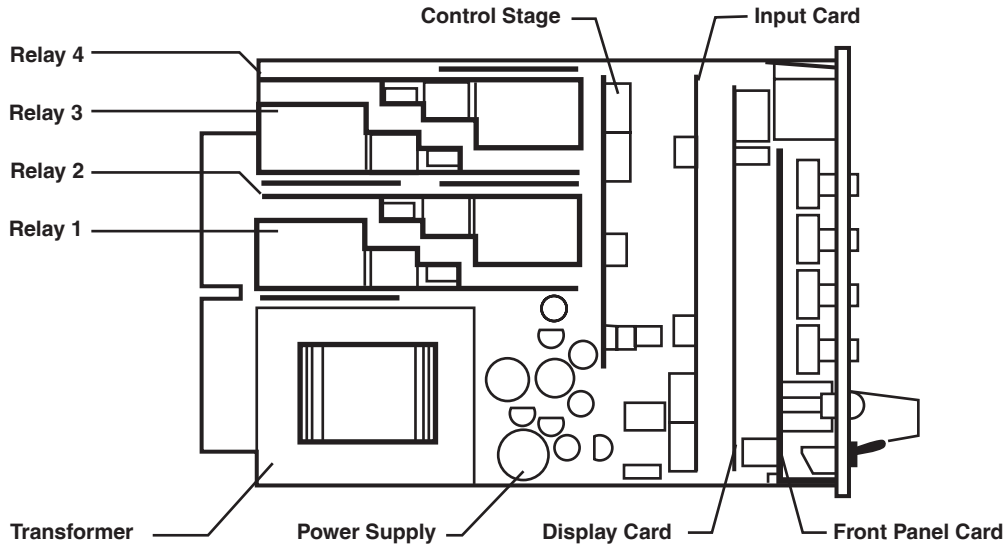

### INPUT CARD THERMISTOR

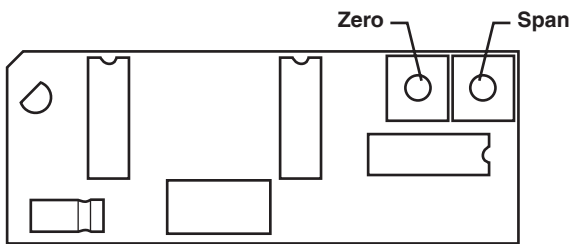

The TC2000 can be used with all major temperature sensing devices. However a different input conditioning card is required for each type. The most common are:

#### Thermistor

An NTC thermistor is linearised to an accuracy better than  $\pm 0.2^\circ\text{C}$  over the range of  $-40$  to  $100^\circ\text{C}$ . Sensors are available in room, duct, pipe, encapsulated and averaging.

### INPUT CARD 4 - 20 mA

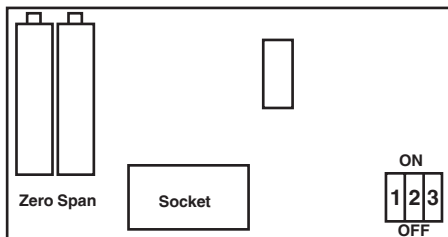

#### Thermocouple, PT100, PT1000

The TC2004 is used with any 4 - 20 mA temperature sensor, two or three wire connection. The TC2004 has a 12VDC supply available from terminal 1 for loop powered devices. If a higher voltage is required, then an external power supply is connected to the sensor (+) and terminal 3 (signal ground). The sensor output (-) is connected to terminal 2 (input). For three wire devices, connect to terminals 1, 2 & 3. The zero and span potentiometers can be used to adjust the 4 - 20 mA signal to display a range from 50 to 1050. Dip switches 1 & 2 are used to set the decimal points. Dip switch 3 is not used.

#### 2 - WIRE CONNECTION

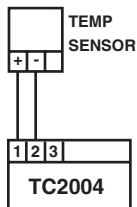

#### 3 - WIRE CONNECTION

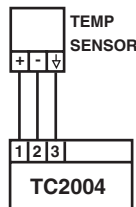

#### EXTERNAL POWER SUPPLY

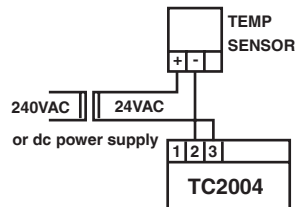

#### EXTERNAL POWER SUPPLY - 3 WIRE

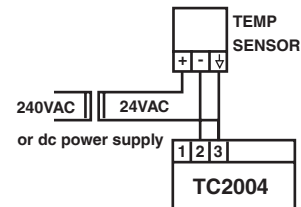



# Regulator Systems

MANUFACTURER OF AIR CONDITIONING CONTROLS AND INSTRUMENTATION

## TC2000 TEMPERATURE CONTROLLER

### CONTROL STAGE

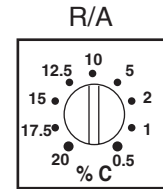
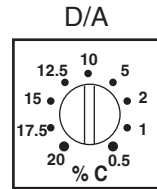
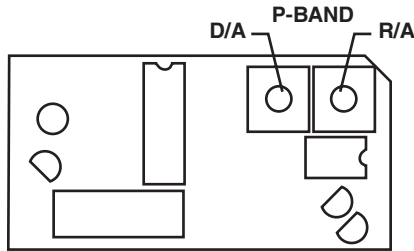

### PROPORTIONAL OUTPUTS

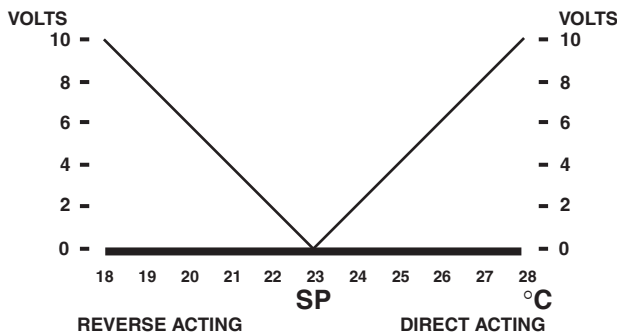

#### Proportional Band

The TC2000 generates two voltage signals, D/A direct acting and R/A reverse acting. Each is independently adjustable. These 0 - 10vdc signals are proportional to the deviation of the Input temperature to the setpoint. For the Thermistor input, the adjustment range is from 0.5 - 20°C. E.G. With a P-Band setting of 5°C, this will give a 0 - 10vdc output with a 5°C change at the sensor. For the 4 - 20mA input, the adjustment range is from 0.5 - 20% of range. E.G. If a thermocouple input range is 0 - 500°C and with a P-Band setting of 2%, this will give a 0 - 10vdc output with a 10°C change at the sensor.

### RELAY CARD

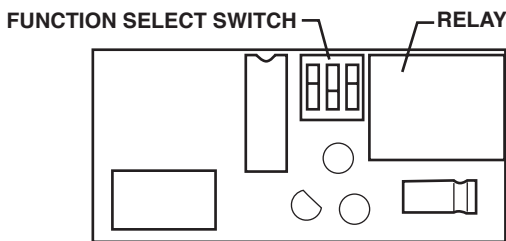

#### Functional select switches - example settings

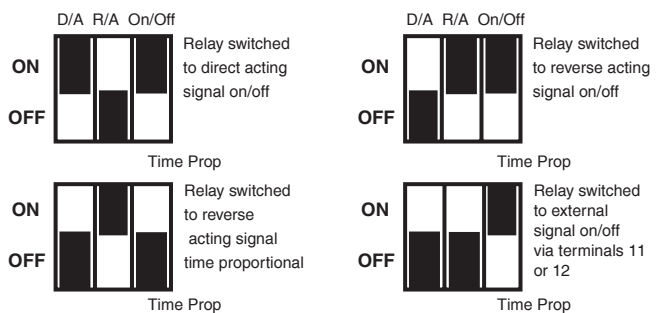

#### Relay Cards

The TC2000 relay cards have identical features:

1. Easy plug in replacement with expansion to 4 outlets.
  2. 240VAC 2.5 amp ratings with voltage-free contacts.
  3. Selection for operation of each relay stage on the D/A or R/A voltage signal.
  4. Selection of each stage to operate as ON/OFF or TIME PROPORTIONAL basis with DIP switching.
- Relays 3 & 4 can be isolated from the internal D/A and R/A signal rails and operated through terminals 11 & 12 by an external 0-10VDC signal. The diagram shows the DIP switch positions.



# Regulator Systems

MANUFACTURER OF AIR CONDITIONING CONTROLS AND INSTRUMENTATION

## TC2000 TEMPERATURE CONTROLLER

### TECHNICAL DATA

Supply Voltage	240v ± 10% 24v ± 10%	Weight	max 0.2kg
Power Consumption	2VA	Size	H: 140mm W: 48mm D: 170mm
Ambient Temperature		Output	D/A + R/A 0 to 10VDC 10mA max High Select D/A + R/A 0 to 10VDC 10mA max
Operating	0 to 50°C	Relay Outputs	SPDT Contacts - Voltate Free 250VAC 2.5A
Storage	-20 to 60°C		
Ambient Humidity	max 90% RH		
Enclosure	Flame retardant ABS		

### TERMINAL CONNECTION DIAGRAM

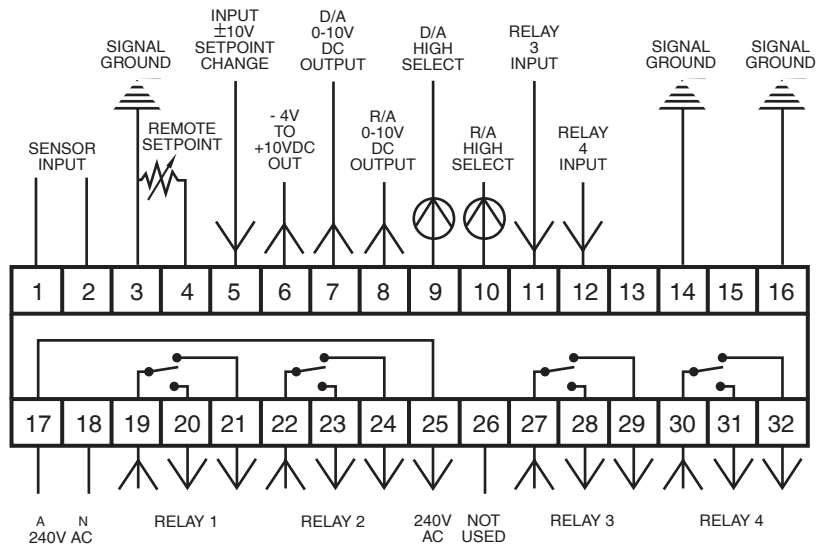

### MODEL NUMBERING SYSTEM

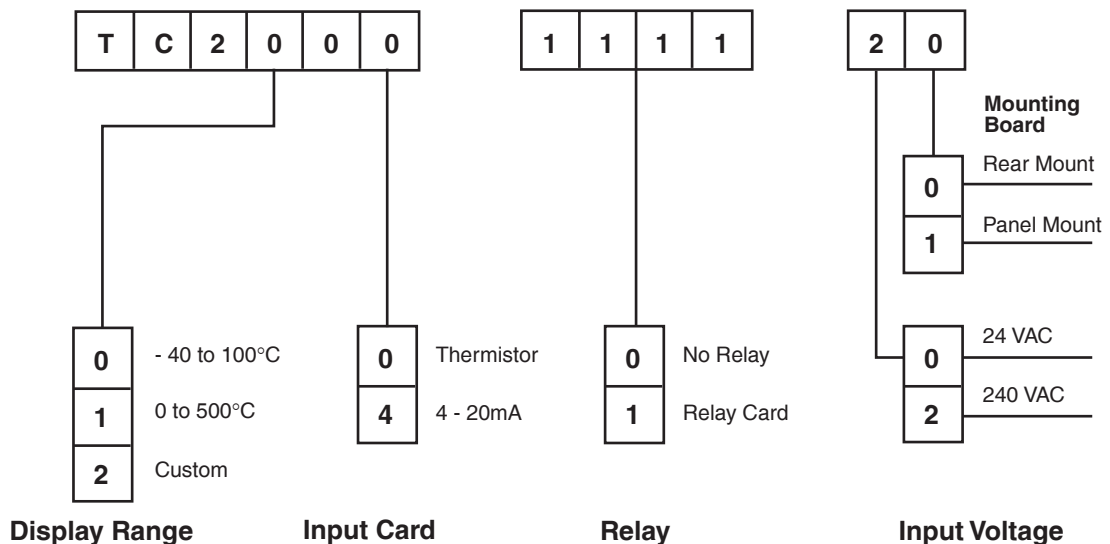



## TC2000 TEMPERATURE CONTROLLER

### MODEL NUMBERING SYSTEM

#### Sensor Inputs

There are several inputs available for the TC2000:

1. THERMISTOR An NTC thermistor (internally linearised) supplying the  $-40^{\circ}\text{C}$  to  $+100^{\circ}\text{C}$  range. Available as switchplate mounted, duct or encapsulated formats. Accuracy to  $\pm 0.2^{\circ}\text{C}$ .
2. 4 - 20mA. Any temperature sensor that has a 4 - 20mA output. E.G. Thermocouple, RTD, etc.

#### Common Signal Ground

All signal inputs and control voltage outputs are referenced to this point. In multiple control configurations, #3 must be commoned.

#### Remote Setpoint

If a remote setpoint is required, it is wired across terminals 3 & 4. The common temperature setpoint has a range of  $18 - 28^{\circ}\text{C}$ . Other ranges are  $10 - 35^{\circ}\text{C}$  and  $0 - 50^{\circ}\text{C}$ .

#### Setpoint Change

This terminal accepts a  $+10\text{v}$  to  $-10\text{v}$  signal to vary the setpoint up and down  $\pm 20^{\circ}\text{C}$ . Commonly this signal would be derived from a DDC or BMS system, or another controller. The altered setpoint is displayed on the EXT S.P. position on the front panel. The INT EXT switch is set to INT.

#### -4v to +10v DC

This terminal output is a direct output voltage representation of the input signal. In the TC2000 it represents  $-40^{\circ}\text{C}$  to  $+100^{\circ}\text{C}$ . Commonly used to interface with a DDC or BMS system.

NOTE: If there is a sensor fault and the controller shuts down, this voltage drops to  $-15\text{VDC}$  allowing for an external fault indicator to be incorporated.

#### D/A & R/A 0-10VDC Output

When switched to the D/A or R/A position, these outputs voltages are the same as shown on the front panel digital display. These voltages are generated by the TC2000 in

response to movement away from the setpoint of the measured variable (e.g. temperature, humidity, etc.) and are the voltage ramps used to switch the internal relays. Used for analog output for external equipment control.

#### D/A & R/A High Select

These terminals are used for high selecting on multiple control hookups. Voltages are the same as for 0-10 output terminals. Diode protected to prevent voltage feeding back into the controller.

#### Relay 3 & 4 Input

When it is desired to operate a relay from an external signal then the dip switch settings on the relay card are switched to external signal. These external signals are connected to terminal 11 for relay 3 and terminal 12 for relay 4.

#### 240VAC/24VAC

All System 2000 Controllers have internal mains transformer isolation. Active supply is via terminals 17 & 18. Terminals 19 to 32 are relay connections. Relays are rated 2.5 amps at 240VAC.

### DIN MOUNTING RAIL

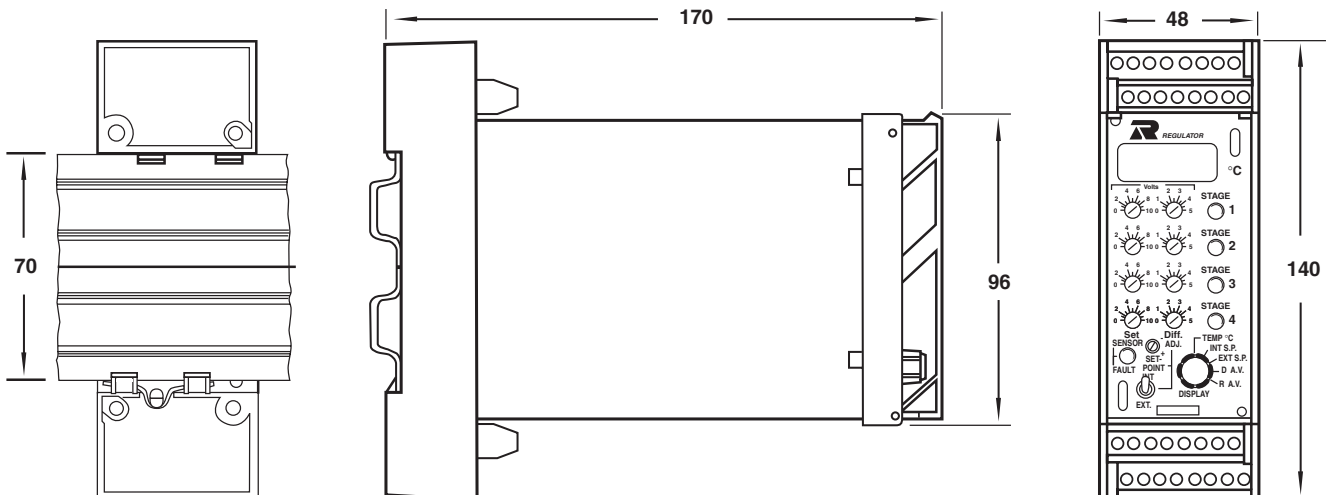

NOTE: Double 35 mm DIN Rail



# Regulator Systems

MANUFACTURER OF AIR CONDITIONING CONTROLS AND INSTRUMENTATION

## TC2000 TEMPERATURE CONTROLLER

### PANEL OR REAR MOUNTING

All TC2000 Controllers are suitable for panel or rear mounting. Available in a white custom-made enclosure, the TC2000 can be mounted through the front panel of a switchboard to take full advantage of the digital display. Wiring is easy. The DIN rail (spring loaded clip system) supports the minimum of interconnections with all signal and high voltages at opposite ends.

### PANEL MOUNT TERMINAL BLOCK

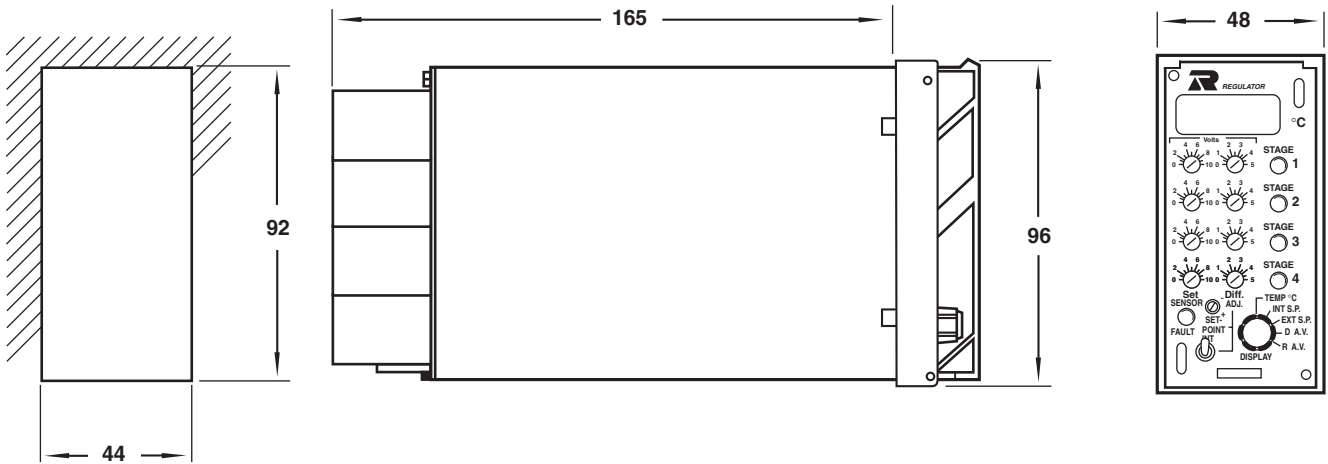

CUT OUT - DIMENSIONS